

TECHNICAL DATA

PNEUMATIC TIRED ROLLERS

BW 11 RH-5

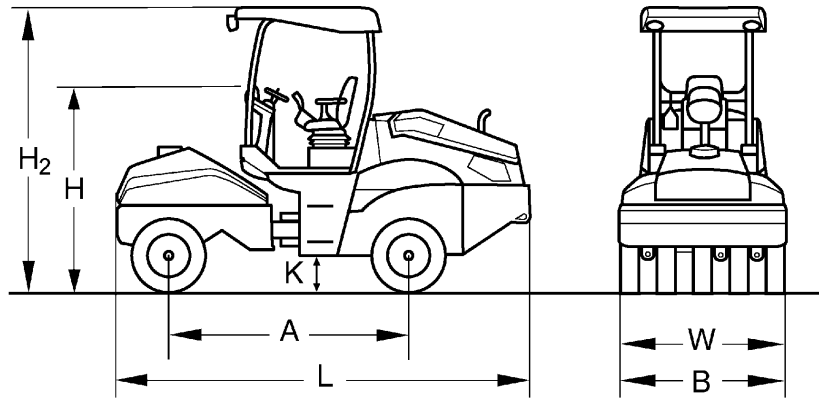



Dimensions in inch

	A	B	H	H2	K	L	W
BW 11 RH-5	98.4	75.6	82.1	113.0	15.0	174.4	68.0

Shipping dimensions in cub.yd

BW 11 RH-5

without ROPS

23,197

with ROPS

31,928

Machine type	Compaction output (t/h) at different asphalt layer thicknesses		
	0.8-1.6 in	2.4-3.1 in	3.9-4.7 in
BW 11 RH-5	117.7-235.4	353.1-470.9	588.6-706.3

Technical Data

BOMAG BW 11 RH-5

Weights

Operating weight w. ROPS CECE	lb	11,464
Operating weight CECE w. ROPS-cabin	lb	11,905
Grossweight	lb	24,251
Max. middle wheel load CECE	lb	2,694

Dimensions

Track radius, inner	in	122.0
---------------------------	----	-------

Driving Characteristics

Speed (1)	mph	7.5
Speed (2)	mph	9.9
Speed (3)	mph	12.4
Max. gradeability (dep. on soil con.)	%	20

Drive

Engine manufacturer		Kubota
Type		V3307 CR-T
Emission stage		Stage V / TIER4f
Exhaust gas aftertreatment		DPF
Cooling		Liquid
Number of cylinders		4
Performance ISO 14396	hp	74.3
Performance SAE J 1995	hp	74.0
Electric equipment	V	12
Drive system		hydrost.
Driven axles		rear

Tires

Tire size		7.50x15 14PL
Wheel track overlap	in	
Number of tires, front / rear		5/4

Steering

Steering system		oscil.artic.
Steering method		hydrost.
Steering angle +/-	deg	35
Oscillating angle +/-	deg	10.0
Oscillation of tires, front	deg	5

Capacities

Fuel	gal	52.8
Water	gal	140.0

Technical modifications reserved. Machines may be shown with options.

Standard Equipment

- Operator's platform with:
 - + Steering wheel
 - + Travel lever
 - + Operator seat
- Control panel for
 - Engine oil pressure
 - Engine temperature
 - Air filter vacuum
 - Hydraulic oil filter
 - Coolant level
 - fuel tank capacity
- Hour meter
- Warning horn
- Lockable anti vandal dashboard protection
- Back-up alarm

Optional Equipment

- * ROPS/FOPS with safety belt
- * ROPS-cabin with heating
- * ROPS cabin with air conditioning
- Radio
- Swivel seat (+40°/-10°)
- Indicator and hazard lights
- Rotary beacon
- Additional lighting for cabin
- Pointer
- Pressure sprinkler system/Scrapers
- Spraying system for scraper, coco fibre
- Spraying system for scraper, brush
- Central tire inflating system
- Thermal aprons
- Brake release device
- Backup warning buzzer with broadband technology
- Special painting
- Additional weight
 - 15,432lb Grossweight
 - 19,842lb Grossweight
 - 24,251lb Grossweight
- TELEMATIC

* Standard delivery with CE conformity
(valid within European Union)

