

CONCRETE BATCH PLANT PARTS CATALOG

Supplying Batch Plants and Parts Since 1956

www.cmw-equip.com



CMW

Equipment



*Supplying parts for all major manufacturers including
Stephens • Ross • CMI Johnson Ross • R&S • Liddell*

*** DON'T SEE THE PART YOU NEED? JUST ASK! ***

800.283.1336

CMW Equipment is a full service equipment dealer that has been in business since 1956. We have parts, service, and sales for everything around a concrete plant except the rolling stock (loaders and trucks). We have knowledgeable people that can help you with parts for plants, stationary mixers, conveyors, silos, controls, dust collectors, water pumps, water recycling, hot water heaters, and chillers.



Badger Meter, Inc.



Table of Contents

Aeration Components	2	Solenoid Valves	52
Air Fittings.....	3	AAA Solenoids & Solenoids Repair Kit.....	53
Air Cylinders	4	Sprockets & Chains	54
Belt Wipers	5, 6	Transition Kits	55
Belting Components	7	Current Batcher Transition	56
Harness Sketch	8	Silo Transition Assembly	57
Air Accessories.....	9	Stephens Discharge Heads	58
Bearings	10	Air Vibrators Turbo Type.....	59
Bindicators Accessories.....	11	Handles & Flanges.....	60
Bray, Weco, & Demco Butterfly Valves.....	12	Water Meter Components.....	61
Bray & WAM Butterfly Valves	13	Water Pumps & Hose.....	62
Duct Work.....	14-15	Aeration Blower	63-64
Control Panel Components	16	Turn Heads and Flop Chutes	65
Electrical Components	17-18	Magnehelic Gauge Kit	66
Fill Line Parts	19	Batcher Vents	67
Gates	20	Silo "Bag Type" Vent.....	68
Ross and Johnson-Ross Plant Parts.....	21	Silo "Cartridge" Vent.....	69
Boots	22	Griffin/Belgrade/Ross and WAM Collector Parts	70
110 VAC Coil Assemblies.....	23	C&W Parts - Gauges, Shrouds, & Liftframes	71
2 Way Solenoid Valves	24	C&W Parts - Return Blower Components.....	72
Parker 4 Way Solenoid Valves.....	25-26	C&W Parts - Ducting.....	73
Ross Idler Assemblies.....	27	C&W Cartridge Pulse Collector	74
WAM Butterflies	28-29	C&W RA-140 Central Collector Components	75
Johnson 12 YD Drum Poly Liners.....	30	C&W Auto Recycle 7.5 HP	76
Ross Mixer Poly Liners.....	31	C&W LPR-6/8	77
Johnson & Ross Mixer Drums.....	32	C&W Silo Collector Parts	78
Johnson Mixer Hyrdraulic Unit.....	33	Silo Collector Round.....	79
Johnson Mixer Components	34	Long Transfer Conveyor Parts	80
Ross Mixer Components Paddles & Bolts	35	Radial Stacker & Truss Conveyor	81
Ross Mixer Components - Bearings & Seals.....	36	Radial Stacker & Truss Conveyor	82
Ross Drive Components.....	37	Screw Conveyor Reducer Drive 9"	83
Ross Hydraulic Cylinders & Components.....	38	Screw Conveyor Reducer Drive 12".....	84
Ceramic Liners	39	Screw Conveyor Direct Drive 9"	85
Stephens AR Liner for Aggregate Scale.....	40	Screw Conveyor Direct Drive 12"	86
4 Compartment Stephens AR Liner fot Aggregate Bin.....	41	Screw Conveyor Direct Drive	87
3 Compartment Stephens AR Liner for Aggregate Bin.....	42	Screw Conveyor Jackshaft Drive 6 & 9"	88
Idlers.....	43-44	Screw Conveyor Spline Drive	89
Head & Tail Pulleys	45	Johnson & Ross Screw Conveyor Components.....	90-91
Scale Levers	46	Matec Filter Press.....	92
Blow Back Blower Components	47	Pearson Heater & Tank Parts.....	93-94
Motors & Reducers.....	48	Airline & Concrete Chipping Accessories & Rental.....	95
Remotes.....	49-50	Redline RM Series	96-98
Overfill Protection	51	Stephens Workhorse Mixer/Inventure.....	99

Stephens Manufacturing Factory



Our line of Concrete Plants And more



Aeration Components

Letter	Description	Part #
A	Aeration Pad Monitor	AE3-8511-903
B	Mounting Kit	AE3-8010
C	Monitor Aeration option 3 Flo Pads	Monitor 8-8011
D	1" Aeration Straight Fittings with 1/2" Tees 1/2" MPTX3/8 Barb Tee	U251000 RR99048
E	3/4" Aeration Tees	WP4518
F	3/4" Aeration Elbows	WP4519
G	Replacement Screen	P/N CF0251
H	Snap Ring	P/N 69-12
I	Solimar Aeration Cone (compressor)	4300

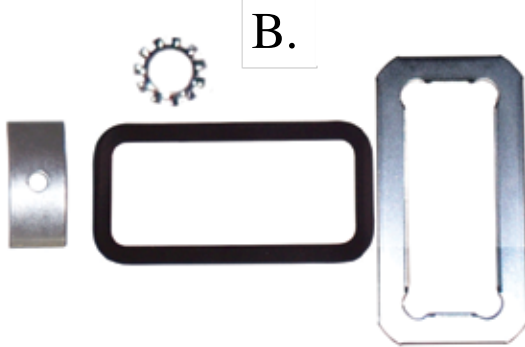

Description	Part #
Aeration Manifold	AM895623 50

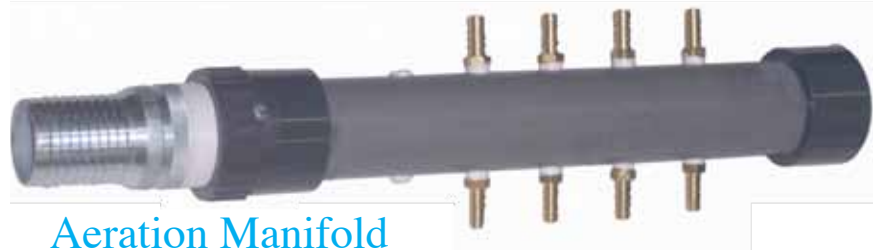

Air Fittings

Description	Part #
3/8" Hose Barb Insert for Compression Fittings	CSA-3/8"
3/8" COMP X 1/8" MPT 90 Degree Fitting Brass	18-232
3/8" COMP X 1/8" MPT STR Fitting Brass	18-187L
3/8" COMP X 1/4" MPT 90 Degree Fitting Brass	18-233
3/8" COMP X 1/4" MPT 45 Degree Fitting Brass	18-333
3/8" COMP X 3/8" MPT 90 Degree Fitting Brass	18-234
3/8" COMP X 1/2" MPT 90 Degree Fitting Brass	18-235
1/4" COMP X 1/8" MPT 90 Degree Fitting Brass	18-224
1/4" COMP X 1/8" MPT STR Fitting Brass	18-179L
1/4" COMP X 3/8" MPT STR Fitting Brass	18-210
1/4" COMP X 3/8" MPT 90 Degree Fitting Brass	18-226
3/8" BARB X 1/8" MPT SRT Fitting Brass	32-011
3/8" BARB X 1/8" MPT 90 Degree Fitting Brass	32-046
3/8" BARB X 1/4" MPT SRT Fitting Brass	32-006
3/8" BARB X 3/8" MPT SRT Fitting Brass	32-013
3/8" BARB X 3/8" MPT 90 Degree Fitting Brass	32-042
3/8" BARB X 1/2" MPT 90 Degree Fitting Brass	32-047
3/8" BARB X 1/2" MPT SRT Fitting Brass	32-014
3/8" Union Tee Barb Fitting Brass	32-126
1/8" NPT X 1/8" MPT X 1/8" NPT Tee Female Brass	BRT 18
1/2" NPT X 1/2" MPT X 1/2" NPT Tee Female Brass	BRT 12
1/4" Flow Restrictor Bimba	FCP-4
3/8" Flow Restrictor Bimba	FCP-6
1/2" Flow Restrictor Bimba	FCP-8



Brass Fittings

Description	Part #
2-1/2" X8" Air Cylinders	ST3P225X8SP5300
2-1/2" X12" Air Cylinders	ST3P225X12SP530
2-1/2" X18" Air Cylinders	ST3P225X18SP5300
3-1/4" X8" Air Cylinders	ST3P2325X8SP5300
3-1/4" X10" Air Cylinders	ST3P2325X10SP5300
4" X 8" Air Cylinders	ST3P2485P5300
4" X10" Air Cylinders	ST3P24X10SP5300
4" X12" Air Cylinders	ST3P24X12SP5300
5" X8" Air Cylinders	ST3P25X8SP5300
5" X10" Air Cylinders	ST3P25X10SP5300
5" X12" Air Cylinders	ST3P25X12SP5300

Air Cylinders



Note: Other Cylinders are available

1 1/2" - 12" BORE
Pressure rating:
250 psi air
or oil service.
Stock stroke
for 1 1/2" to 5" bores:
1", 2", 3", 4", 5",
6", 8", 10", 12".

Stroke lengths to
suit are available in
all bore sizes

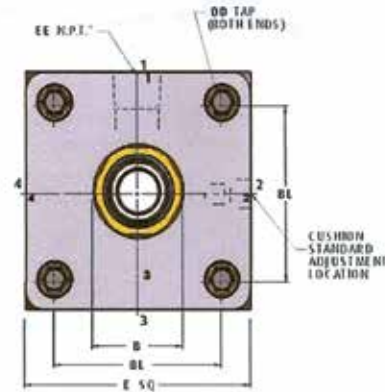
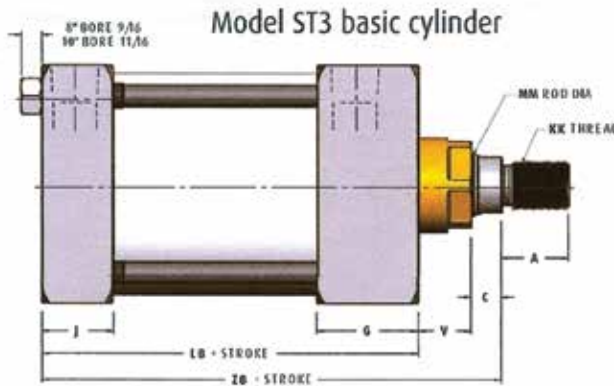

BORE	1 1/2	2	2 1/2	3 1/4	4	5	6	7	8	10	12
A	3/4	3/4	3/4	1 1/8	1 1/8	1 1/8	1 5/8	1 5/8	1 5/8	2	2.25
B	1.124	1.124	1.124	1.499	1.499	1.499	1.999	1.999	1.999	2.374	2.624
BL	1.43	1.84	2.19	2.78	3.32	4.12	4.88	5.730	6.44	7.92	9.406
C	3/8	3/8	3/8	1/2	1/2	1/2	5/8	5/8	5/8	3/4	7/8
DD	1/4-28	5/16-24	5/16-24	3/8-24	3/8-24	1/2-20	1/2-20	5/8-18	5/8-18	3/4-16	3/4-16
E	2	2 1/2	3	3 3/4	4 1/2	5 1/2	6 1/2	7 1/2	8 1/2	10 5/8	12 3/4
EE	3/8	3/8	3/8	1/2	1/2	1/2	3/4	3/4	3/4	1	1
G	1 1/2	1 1/2	1 1/2	1 3/4	1 3/4	1 3/4	2	2	2	2 1/4	2 1/4
J	1	1	1	1 1/4	1 1/4	1 1/4	1 1/2	1 1/2	1 1/2	2	2
KK	7/16-20	7/16-20	7/16-20	3/4-16	3/4-16	3/4-16	1-14	1-14	1-14	1 1/4-12	1 1/2-12
LB	3 5/8	3 5/8	3 3/4	4 1/4	4 1/4	4 1/2	5	5 1/8	5 1/8	6 3/8	6 7/8
MM	5/8	5/8	5/8	1	1	1	1 3/8	1 3/8	1 3/8	1 3/4	2
V	5/8	5/8	5/8	7/8	7/8	7/8	1	1	1	1 1/8	1 1/8
ZB	4 5/8	4 5/8	4 3/4	5 5/8	5 5/8	5 7/8	6 5/8	6 3/4	6 3/4	8 1/4	8 7/8

Repair Kit for Cylinders

Kit for 5" Taigo CYL SSK-2-500-CS

Description	Part #
Kit for 2-1/2" Star Cylinder	ST3TSK25000625
Kit for 3-1/4" Star Cylinder	ST3TSK32001000
Kit for 4" Star Cylinder	ST3TSK40001000
Kit for 5" Star Cylinder	ST3TSK50001000
Kit for 3-1/4" Taiyo & Cylinder	SSK-2-325-CS
Kit for Wabco Cylinder 3 1/4X8	P-068153/068149

Other Sizes available





Part #	Description
WP-10-226-00102	24" Red Wiper Blade
WP-10-226-00202	30" Red Wiper Blade
WP-10-226-00302	36" Red Wiper Blade



Part #	Description
P/N CP-Mea-28M-G83	30" Micro Eraser Beltwiper

Part #	Description
P24STBWBA89	24" Titan Beltwiper Blade

Part #	Description
P24STBW19	24" Titan Beltwiper Assembly



Part #	Description
P/N CP-MR-28-G83	30" Micro Eraser Blade Only

Part #	Description
P36STBWBA89	36" Titan Beltwiper Blade

Part #	Description
P36STDW19	36" Titan Beltwiper Assembly



Part #	Description
P/N- BW240	24" Belt Wiper Blade

Belt Wipe Accessory



Part #	Description
PUDSTBWTN59	Belt Wiper Tensioner



Part #	Description
PUDSTBW3BRG69	Belt Wiper 3" Long Bearing



Part #	Description
SC11916	1 9/16 Set Collar



Part #	Description
PUDSTBWTG39	Belt Wiper Torque Guide



Part #	Description
P30STBWF29	30" Belt Main Frame



Part #	Description
821-4165	5/32 X 2 15/16 Hair Pin



Part #	Description
PTIT-38Q	Wiper Blade Safety Pin



Part #	Description
PUDSTBWRW99	Belt Wiper Retain Washer



Part #	Description
PTENPIN14	Belt Wiper Tensioner Pin
SNPP03103940	Belt Wiper Tensioner Pin

Belting Components

Description	Part #
24" Belting (3/16 X 1/16 X 220)	24-220-2PLY
30" Belting (3/16 X 1/16 X 220)	30- 220-2PLY
36" Belting (3/16 X 1/16 X 220)	36- 3-PLY
3/8" X 8" Skirt Board Materials	SB6X8
3/8" X 14" Skirt Board Materials	SB6X14
1/2" X 6" Skirt Board Materials	SB8X6
1/2" X 8" Skirt Board Materials	SB8X8
1/2" X 24" Skirt Board Materials	SB8X24
1/2" X 30" Skirt Board Materials	SB8X30
1/2 X 24" Gum Rubber Skirtboard	PG 1/2-48

140 E Flexco Solid Fasteners

Description	Part #
HP1 Flexco Punch for 140E	HP1
HW1 Flexco Wrench for 140E	HW1
110 Flexco Bolt Breaker	110
24" Templet for 140E Fasteners	140-24
30" Templet for 140E Fasteners	140-30
36" Templet for 140E Fasteners	140-36
140E Belt Fasteners 25-per Box	Fastners 140E

375 Flexco Hinged Fasteners

Description	Part #
HP1 Flexco Punch	HP1
H100 Flexco Wrench for 375X	H100
110 Flexco Bolt Breaker	110
Flexco Hinged Fastner with PIN	375XJ24
Flexco Hinged Fastner with PIN	375XJ30
Flexco Hinged Fastner with PIN	375XJ36
Flexco Hinged Templet	375X24
Flexco Hinged Templet	375X30
Flexco Hinged Templet	375X36
1/4" X 24" Armored Steel PIN	NAC-24
1/4" X 30" Armored Steel PIN	NAC-30
1/4" X 36" Armored Steel PIN	NAC-36

Description	Part #
24" Belt Splice Kit	R5-SE-24/600
30" Belt Splice Kit	R5-SE-30/750
36" Belt Splice Kit	R5-SE-36/900

375 Hinged Fastner



Conveyor Belting



Skirt Board Rubber



140E Belt Fastner





7.0 SPECIFICATIONS

7.1 All top and bottom brackets, cable guides, carrier cable, and fasteners are made of galvanized or stainless steel. Contact DBI/SALA for material specification details if required. The LAD-SAF system, when installed according to user instructions, meet OSHA and ANSI requirements, including ANSI A14.3.

8.0 LABELING

8.1 This label must be securely attached and fully legible:

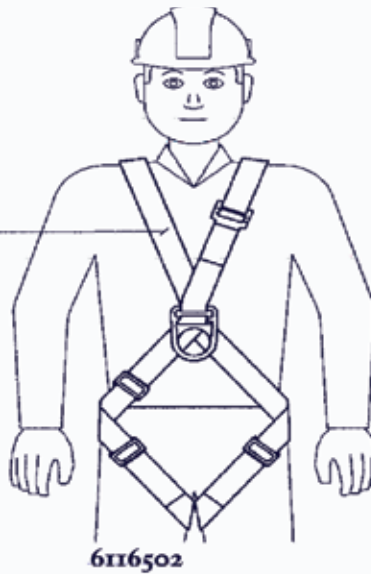
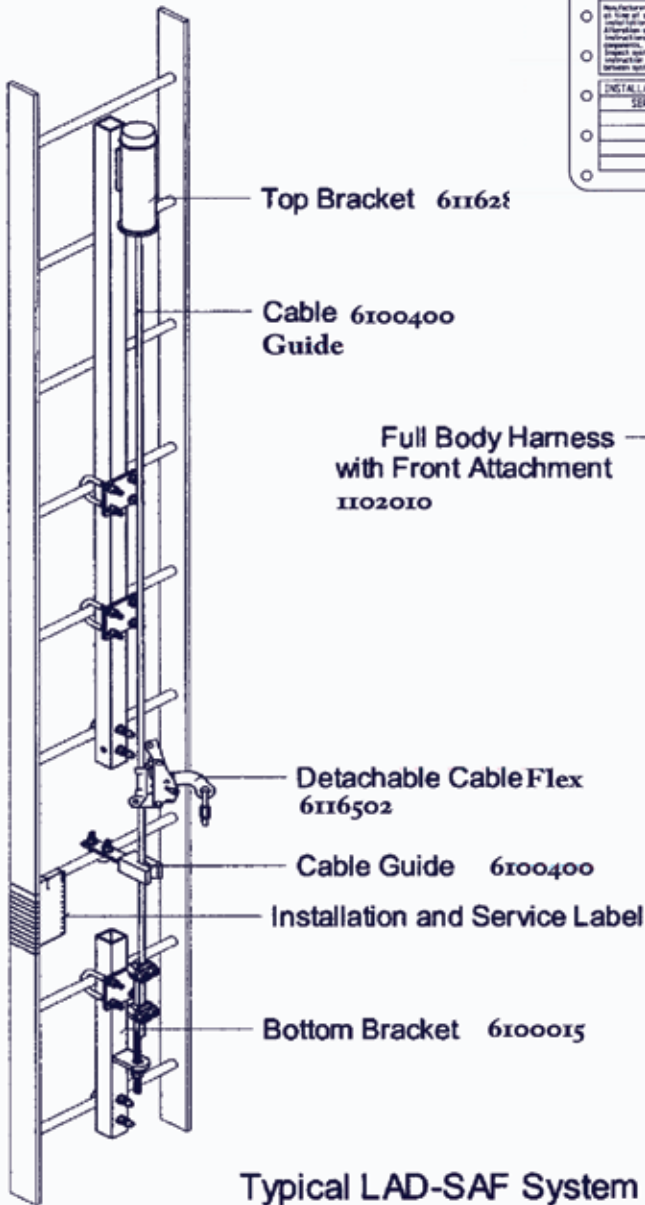
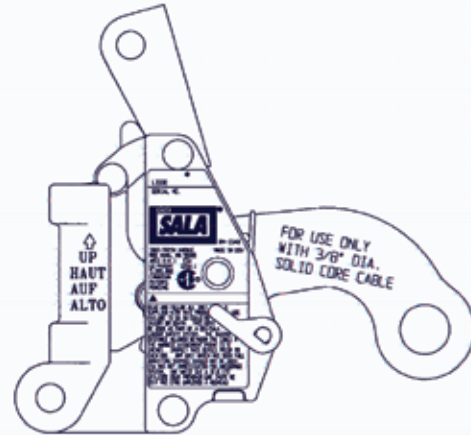
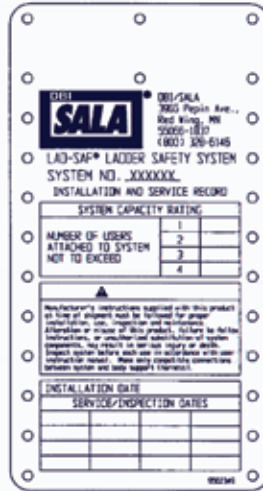

Harness Sketch

Description	Part #
Air Hose Clamps 3/8"	6203
Bag Clamps	5612852
Hose Boot Clamps	6322452
3" Hose Clamps	6844



Stainless Steel Clamps



2" Hose Clamp P# 6832

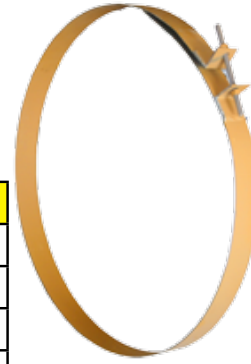

Description	Part #
Metal Clamp for Boot 24"	B-193280-11
Metal Clamp for Boot 22"	B-193280-12
Metal Clamp for Boot 20"	B-193280-13
Metal Clamp for Boot 18"	B-193280-14

Description	Part #
3/8" ID Airline Hose	K1154-06
1/2" Airline Adaptaflex	3204-1334
1/4" I.D. Rubber Hose 200 PSI	3204-1301

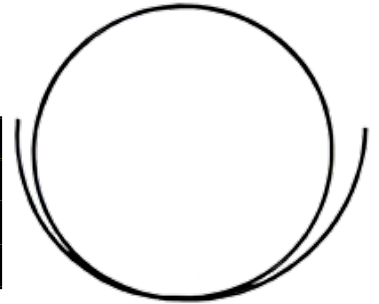

Description	Part #
3/8" Air Hose	K1154-06
1/2" Air Hose	K1154-08



Description	Part #
Filter Regulator	B74G4ATAD3RSN
Lubricator	L74M4APQPN



FRL

Description	Part #
F.R.L Unit Complete	WP-FR1051



FR

Description	Part #
F.R. Unit Complete	WP-FR1050

Pillow Block Bearings

Description	Part #
1/2" Pillow Block Bearing	(123830)
1" Pillow Block Bearing	(123806)
2" Pillow Block Bearing	(126815)
2-7/16" Pillow Block Bearing	(126818)
2-15/16" Pillow Block Bearing	(126821)
3-7/16" Pillow Block Bearing	(126823)
P2B-E-215R Pillow Block Brg	(023017)
P4B-E-507R Pillow Block Brg	(02304)
P2B-K-21R Split Brg	(023183)
3-7/16 Split Bearing	(023186)

Note: Any size Bearings are available

Flange Bearings

Description	Part #
Link Belt Bearing 2"	F3U232N
2" Rexnord Bearing	FB22432H
3" Link Belt Bearings	F3U2E48N
Bearing 3" Bearing for Screw	FB22448HX3
2" Bearing Flop Chute	FX3YZE32N

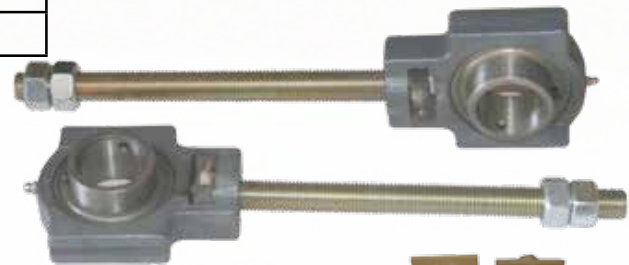

Take Up Bearings

Description	Part #
TU250X1 ^{15/16} Take Up Brg	Tu25011516
2" Dodge Takeup Bearing	125372

Take Up Frames

Description	Part #
Standard Take Up/ Radial Stacker	B391160
For Transfer Conveyor Tube Type	B29424050



Description	Part #
Takeup Frame Trans. o.s.	TU250





Part #	Description
--------	-------------

HGB5774 Low AGG. Bindicators Kit. 12 Ft with wire.
Pre-wired with 30Ft. flexible conduit.

(HGB5774 Comp.) Low AGG. Bindicator Kit 12 Ft.
Less wire

Part #	Description
--------	-------------

HGB6774 High AGG. Bindicators Kit. 4 Ft with wire.
Pre-wired with 30Ft. flexible conduit.

(HGB6774 Comp.) High AGG. Bindicator Kit 4 Ft.
Less wire

Silo & Bin Material Indicators



Part #	Description
--------	-------------

S12B9087 Top mount low Level Bindicator
with 23' Cable & Paddle

Part #	Description
--------	-------------

416-0109 Monitor Bindicator
Motor 115V



Part #	Description
BI-4145	Gardner Single Blade SS Paddle
BI-4141	3 Blade Bindicator Paddle 9" DIA
BI1-4193	Cement Banana Paddle



Part #	Description
--------	-------------

GRSS-1 Coupler for Bindicator
Paddle



Part #	Description
--------	-------------

730-0022 Round mounting
Plate & Gasket
MD-GRMP-1



Part #	Description
--------	-------------

530-0013 Limit Switch ASSY
GR-Series



Part #	Description
--------	-------------

BI 1-8301-1 KA, 115 VAC
Monitor WAM



Part #	Description
--------	-------------

S2B8779 Top mount Hi Level
with 2' Alum. Rod & Paddle



Part #	Description
--------	-------------

6-8511-1112 Monitor Silo Patrol

6-8631-1000 HMI-2 Control

Butterfly Valves

Description	Part #
2"	BF-2
3"	BF-3
4"	BF-4
8"	BF-8
10"	BF-10
12"	BF-12

Actuator

2"+3"	BF-3A
4"	BF-4A
8"+10"	BF-10A
12"	BF-12A



COMPONENTS

No.	Qty.	Description
1	1	Body
2	1	Seat
3	1	Disc
4	1	Stem
5	1	Stem Seal
6	1	Stem Bushing
7	2	Stem Retainer
8	1	Thrust Washer
9	1	Retaining Ring

*FKM is the ASTM D1418 designation for Fluorinated Hydrocarbon Elastomers (also called Fluoroelastomers).
Hastelloy® is a registered trademark of Haynes International, Inc.
Halar® is a registered trademark of Ausimont U.S.A., Inc.

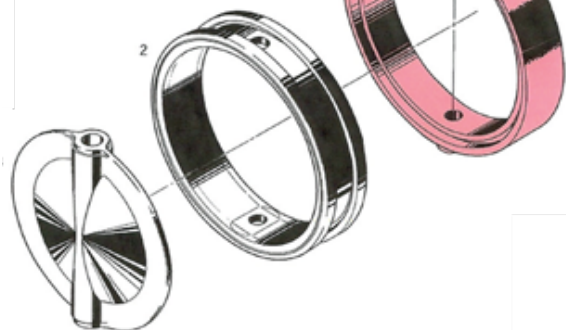

Bray Couplin

Description	Part #
Couplin for 4" Bray Valve	92000B122600536
Couplin for 8" Bray Valve	92000D122600536

Bray Limit Switch

Description	Part #
Limit Switch Bray Actuator	BF-LS
Bray Limit Switch Adaptor Kit	50160024603536
8" Bray Act. Mounting Plate	92118011300532
Bray Solenoid Valve	BF-SV
Bray 8" to 10" Stem Adaptor	BF-01



Vane Actuator

Description	Part #
FMC 200 Vane Actuator	3258068
Repair Kit for FMC 200	3255112



Demco Valves	2", 3", and 4"
Weco Valves	2", 3", and 4"

DIMENSIONS SERIES 30 Wafer

BRAY

SERIES 31 Lug

Valve Size		A	B	C	D	E	F	Mounting Flange Drig.			G	H	J	K
ins	mm							BC	No. Holes	Hole Dia.				
2	50	3.69	1.62	2.00	2.84	5.50	3.54	2.76	4	.39	.55	.39	1.25	1.32
2½	65	4.19	1.75	2.50	3.34	6.00	3.54	2.76	4	.39	.55	.39	1.25	1.91
3	80	4.88	1.75	3.00	4.03	6.25	3.54	2.76	4	.39	.55	.39	1.25	2.55
4	100	6.06	2.00	4.00	5.16	7.00	3.54	2.76	4	.39	.63	.43	1.25	3.57
5	125	7.06	2.12	5.00	6.16	7.50	3.54	2.76	4	.39	.75	.51	1.25	4.63
6	150	8.12	2.12	5.75	7.02	8.00	3.54	2.76	4	.39	.75	.51	1.25	5.45
8	200	10.50	2.50	7.75	9.47	9.50	5.91	4.92	4	.57	.87	.63	1.25	7.45
10	250	12.75	2.50	9.75	11.47	10.75	5.91	4.92	4	.57	1.18	.87	2.00	9.53
12	300	14.88	3.00	11.75	13.47	12.25	5.91	4.92	4	.57	1.18	.87	2.00	11.47

Lug Bolting Data		
BC	No. Holes	Threads UNC-2B
4.75	4	5/8-11
5.50	4	5/8-11
6.00	4	5/8-11
7.50	8	5/8-11
8.50	8	3/4-10
9.50	8	3/4-10
11.75	8	3/4-10
14.25	12	7/8-9
17.00	12	7/8-9

Valve Size		A	B	C	D	E	F	Mounting Flange Drig.			G	J	KEY SIZE	K
ins	mm							BC	No. Holes	Hole Dia.				
14	350	17.05	3.00	13.25	15.28	13.62	5.91	4.92	4	.57	1.38	2.00	.39x.39	13.04
16	400	19.21	4.00	15.25	17.41	14.75	5.91	4.92	4	.57	1.38	2.00	.39x.39	14.85
18	450	21.12	4.25	17.25	19.47	16.00	8.27	6.50	4	.81	1.97	2.50	.39x.47	16.85
20	500	23.25	5.00	19.25	21.59	17.25	8.27	6.50	4	.81	1.97	2.50	.39x.47	18.73

Lug Bolting Data		
BC	No. Holes	Threads UNC-2B
18.75	12	1-8
21.25	16	1-8
22.75	16	1 1/8-7
25.00	20	1 1/8-7

WAM Butterfly Gate

8" Butterfly Boot Gate	V1FS.200.GB
8" Butterfly Flange Gate	V2FS.200
10" Butterfly Boot Gate	V1FS.250.GB
10" Butterfly Flange Gate	V1FS.250
12" Butterfly Boot Gate	V1FS.300.GB
12" Butterfly Flange Gate	V2FS.300
Actuator	CP1o1
Solenoid Valve	ZW.V5.V81
Limit Switch	MIC.23

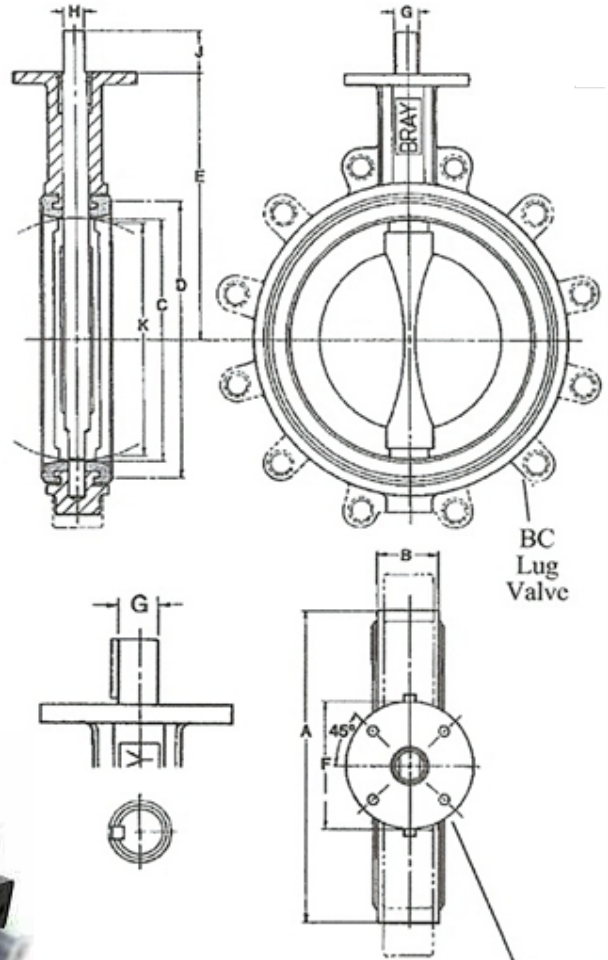



**ROCK-SOLID DURABILITY
WITH THE PERFECT SIZE
AND CONFIGURATION
FOR EVERY APPLICATION.**

INSTRUCTIONS FOR INSTALLING AN ADJUSTABLE NIPPLE

Each QF pipe section is 5 ft. in length.

To shorten to accommodate an existing sponsor, an adjustable nipple is used.



Measure distance to be spanned.

STEP 1

STEP 2



Mark distance to be spanned less 4".



Use O-ring provided and mark for cut.

STEP 3

STEP 4



Drill access hole then cut with saw.



Cut piece of pipe put O-ring on cut pipe, slide nipple over.

STEP 5

STEP 6



Snap clamp over O-ring and one end of nipple.

FINISHED CONNECTION USING THE ADJUSTABLE NIPPLE ASSEMBLY.



ORDERING

NOTES:

UNLESS SPECIFIED, 4" THROUGH 22" IS QF, OVER 22" IS FLANGED. DATA SUBJECT TO CHANGE WITHOUT NOTICE.
STAINLESS STEEL COMPONENTS REQUIRING FLANGES WILL BE SUPPLIED WITH SS FLANGES UNLESS OTHERWISE SPECIFIED.
STAINLESS STEEL COMPONENTS ARE MANUFACTURED WITH NO.304 SS. (PRICES FOR SS 316 = SS 304 X 1.25)
ADDING A SS AFTER STANDARD PART NUMBERS SPECIFIES A SS PART.
FOR SPECIAL PARTS OR ITEMS TO BE CUSTOM MANUFACTURED, CONTACT CMW

Galvanized Quick-Fit Duct for Vents & Silos.



Description	Part #
16" Diameter Pipe X 5' Long	3200-1600
16" Diameter 90 Degree Elbow High Pressure Duct	3210-1690
6" Pipe X 5' Long	3200-0600
6" Diameter 90 Degree Elbow High Pressure Duct	3210-0690
8" Pipe X 5' Long	3200-0800
8" Diameter 90 Degree Elbow High Pressure Duct	3210-0890

Note: Sizes 4" through 22" in Stock and available

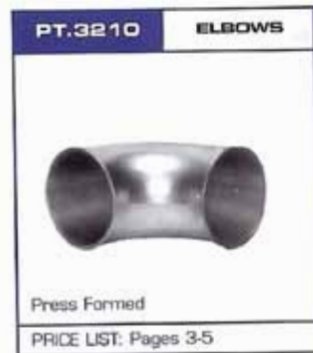
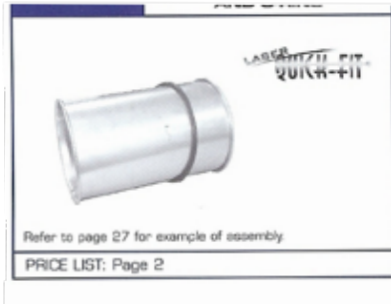

Duct Work

Module #	Push Button Control Box
ZB4BT4	Push Button E - Stop 40MM
ZBY9330	Emergency Stop Circular Legend
ZB4BS44	Mushroom Head Turn to Release
ZB4BC4	Mushroom Head Momentary (Non Ill)
XB4BT4	Mushroom Head Push Pull W/N.C Cont. (Non Ill.) 40mm
ZB4BD2	2Pos. Maint. (Non Ill.)
ZB4BD3	3Pos. Maint. (Non Ill.)
ZB4BD5	3Pos. Mom. to Center (Non Ill.)
ZB4BG4	2Pos. Maint. Key Switch (Non Ill.)
ZB4BZ009	Mounting Collar
ZB4BZ101	N.O. Contact Block W/Flange
ZBE101	N.O. Contact Block Only
ZB4BZ102	N.C. Contact Block W/Flange
ZBE102	N.C. Contact Block Only
ZB4BV01	7/8" Pilot Light Head (White)
ZB4BV03	7/8" Pilot Light Head (Green)
ZB4BV04	7/8" Pilot Light Head (Red)
ZB4BV05	7/8" Pilot Light Head (Yellow)
ZB4BV06	7/8" Pilot Light Head (Blue)
ZB4BV07	7/8" Pilot Light Head (Clear)
ZB4BVG1	Light Module W/Protected Led (White)
ZB4BVG31	Light Module W/Protected Led (Green)
ZB4BVG41	Light Module W/Protected Led (Red)
ZB4BVG51	Light Module W/Protected Led (Yellow)
ZB4BVG61	Light Module W/Protected Led (Blue)
ZBPO	Clear Rubber Boot
ZB4BW33	Ill. Push Button (Green)
ZB4BW34	Ill. Push Button (Red)
ZB4BK1233	2Pos. Ill. Selector Switch (Green)
ZB4BK1243	2Pos. Ill. Selector Switch (Red)
ZB4BK1253	2Pos. Ill. Selector Switch (Yellow)
ZB4BK1263	2Pos. Ill. Selector Switch (Blue)
ZB4BK1333	3Pos. Ill. Selector Switch (Green)
ZB4BK1343	3Pos. Ill. Selector Switch (Red)
ZB4BK1353	3Pos. Ill. Selector Switch (Yellow)
ZB4BWOG31	Light Module W/Protected Led (Green) N.O. Cont.
ZB4BWOG41	Light Module W/Protected Led (Red) N.O. Cont.
ZB4BWOG51	Light Module W/Protected Led (Yellow) N.O. Cont.
ZB4BWOG61	Light Module W/Protected Led (Blue) N.O. Cont.
ZBY2323	Reset Label for ZB4 Push Button
XS8C40FP260H7	Telemecanique Prox Switch
ZB4BVG3	Light Module W/Protected Led (Green)
ZB4BVG4	Light Module W/Protected Led (Red) N.O. Cont.



Limit Switches

Proximity Switch



Description	Part#
Oper Lever ADI	9007-HA4
Oper Lever 12" Delrin Single Loaded	9007-FA5
Oper Lever 1-3/8"	9007-BA18
Oper Lever 1-1/2"	9007-MA18
Square D Limit Switch	9007-C54B2
Limit Switch	9007-C54B
Limit Switch Arm 3" Arm with Nylon Roller	9007-EA18
Rod Type Lever Arm	9007-FA3
Geared Rotary Limit Switch	CR115E421101
Proximity Switch - Eaton	ELE55BLT1C

Conveyor Safety Stop Switches

Description	Part #
Life Line 4	440E-413043



Emergency Stop Kill Switch (440E-L13043)

Manual Starter Overloads, Contacts & Components

Description	Part #
Locking Attachment	GV1-V02
Auxillary Contacts GV2	GVAE11
Manual Starter 600V 1-1.6A	GV2P06
Manual Starter 600V 1.6-2.5	GV2P07
Manual Starter 600V 2.5A	GV2P08
Manual Starter 600V 4-6 AMP	GV2P10
Manual Starter 600V 6-10A	GV2P14
Manual Starter 600V 9-14A	GV2P16
Manual Starter 600V 13-18A	GV2P20
Manual Starter 600V 17-23A	GV2P21
Manual Starter 600V 24-30A	GV2P32
Manual Starter 600V 30-40A	GV3-P40
Manual Starter 600V 37-50A	GV3-P50
Manual Starter 600V 48-65A	GV3-P65
AUX Contact D Line 1NO - 1NC	LA1DN11
AUX Contact D Line 2NO	LA1DN20
Mechanical Interlock	LAD9RIV
Contactor 3PH 200-600V	LC1D09G7
Contactor 3PH 200-600V	LC1D12G7
Contactor 3PH 200-600V	LC1D18G7
Contactor 3PH 200-600V	LC1D25G7
Contactor 3PH 200-600V	LC1D32G7
Contactor 3PH 200-600V	LC1D40AG7
Contactor 3PH 200-600V	LC1D50AG7
Contactor 3PH 50HP 200-600V	LC1D65AG7
Contactor 3PH 200-600V	LC1D80AG7

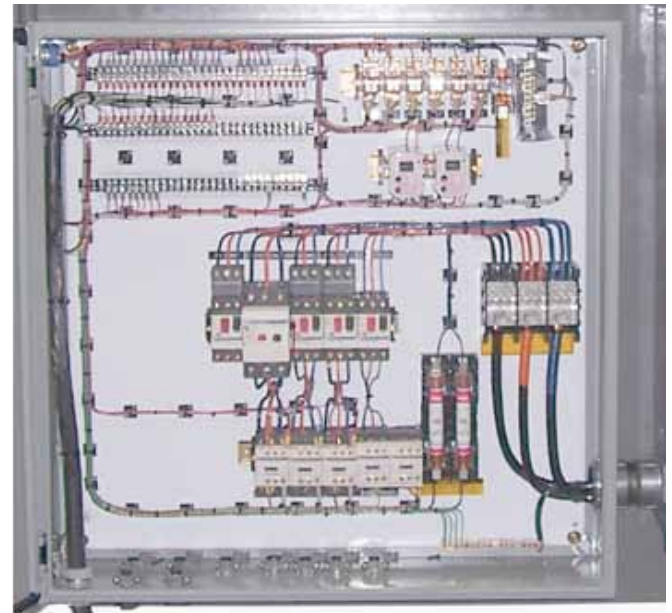

Amperage Chart

For 3 Phase Across the Line Motor Starters

Motor Sizes	208 Volts	230 Volts	480 Volts	575 Volts
1HP	4.14	3.6	1.8	1.4
5HP	17.5	15.2	7.6	6.1
7.5HP	25.3	22	11	9
10HP	32.2	28	14	11
15HP	48.3	42	21	17
20HP	62.1	54	27	22
25HP	78.2	68	34	27
30HP	92.0	80	40	32

Transformer

Description	Part #
.500k VA 240X480Pri 120/240 SEC	500SV1B
.500k VA 600Pri 120/240 SEC	500SV51B
.750k VA 240X480Pri 120/240 SEC	750SV1F
.750k VA 600Pri 120/240 SEC	750SV51F
1kVA 240X480Pri 120/240 SEC	1S1F
1kVA 600Pri 120/240 SEC	1S51F
1.5k VA 240X480Pri 120/240 SEC	1.5S1F
1.5k VA 600Pri 120/240 SEC	1.5S51F
2k VA 240X480Pri 120/240 SEC	2S1F
2kVA 600Pri 120/240 SEC	2S51F
3k VA 240X480Pri 120/240 SEC	3S1F
3k VA 600Pri 120/240 SEC	314F
5k VA 240X480Pri 120/240 SEC	5S1F
5k VA 600Pri 120/240 SEC	5S4F



Relay
8501RS42V20

Timer
328F200F10XX

Relay Bases

Description	Part #
11 Pin	6X156
11 Blade	60SR3B-05
Socket/Base 2 Pole	8501NR42B
8 Pin	5X852
Socket/Base 4 Pole	8501NR34



Relay Bases
8501NR42B

Relay Bases

Timers & Delays

Description	Part #
4 Pole 120 VAC Relay 120VAC	8501RS44V20
2 Pole 8 Blade 120VAC	8501RS42V20
Timer Dayton6A855	6A855
Repeat Cycle 8 PIN .1 SEC -180 Seconds	88867155
On Delay 8 PIN 1.8 SEC - 180 Seconds	5X829
Interval 8 PIN 1.8 SEC - 180 Seconds	6X604
Multi Function.1 SEC - 10 Hours ATC	328F200F10XX
Spring Wound 0-5 Minutes	6X545

Timer
6A855

Timer
5X829F or
6X604F



Relay Bases

Relay Bases

Fill Line Parts

Part #	Description
400AA1	4" Male ADPT Female Thread Coupling
500AA1	5" Male ADPT Female Thread Coupling
400 CAL	4" [Camlock Hose Barb]
400DCAL	4" Dust Cap Aluminum
400B	4" Camlock Gasket
400DCAL-L	4" Locking Dust Cap
500CAL	5" Female Coupler Hose Barb



Part #	Description
ZPFLP4	4" Fill Line Gasket & Bolt Kit
ZPFLP5	5" Fill Line Gasket & Bolt Kit



Part #	Description
H3PF904A	4" Smart Elbow 125# Flange
H4PF905A	5" Smart Elbow 90-Deg



Part #	Description
108628	4" Sch 80 45°-Deg 48" Radius
115238	5" Sch 80 45°-Deg 48" Radius



Part #	Description
90X4 T-Box	Old Style Turbulence Box



Part #	Description
159990	4" Sch 80 90°- Deg 48" Radius
111213	5" Sch 80 90°- Deg 48" Radius



Letter	Description	Parts #
	Complete	Custom Built
A	End Plates	12", 14", 16"

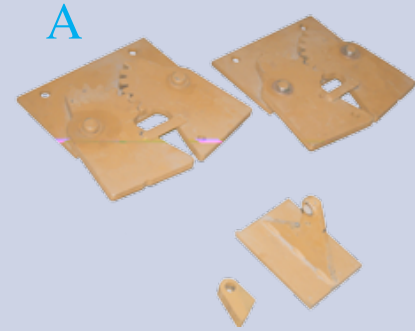

Four Styles to Choose From

Letter	Description	Parts #
B	Skeleton Gates	Link OR Gear Type
C	Box Gates	Link OR Gear Type 17" Tall
D	Low - Profile Box Gates	Link OR Gear Type 12" Tall
E	Super Low Profile Box Gates	Link Type Only 10" Tall

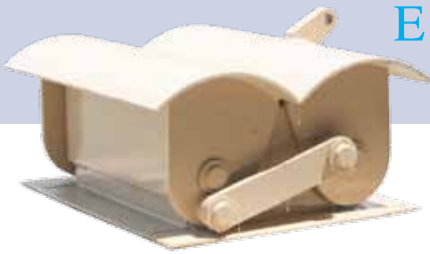

Gate	Description
Skeleton Gates	Link or Gate type
Box Gates	Link or Gate type 17" Tall
Low Profile Box Gates	Link or Gate type 12" Tall
Super Low Profile Gates	Link type only 10" Tall

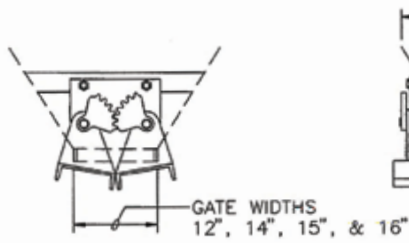

SKELETON GATES

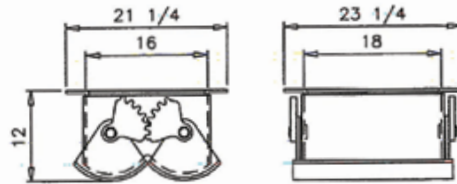
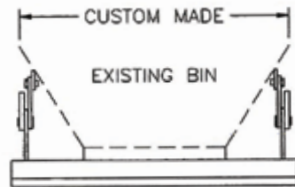

LOW PROFILE GEAR GATE



NOTE
GEAR GATES
ILLUSTRATED...
LINKAGE GATE
ALSO AVAILABLE

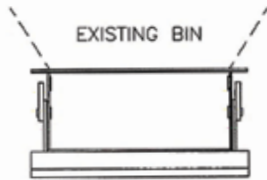

BOLT-ON GATES

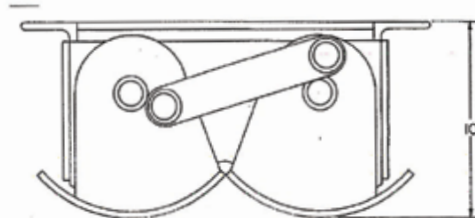

**SUPER LOW PROFILE
LINK GATES**

Discharge (Collection) Hoods		
A	Ross Hood Round with V-Plate	RS-51
B	Ross Hood Oval with Pipe	RS-52
	Ross Explorer Hood	RD52-E
	Ross Explorer Hood	RS51-E



Aggregate Gate		
C	Ross Gear Plate	8 INCH GP
	Ross Grease Bolt	BR1X 3-1/2
D	4" x 8" Schroeder Bellows Cylinder	CY4XBCY
	Proximity Switch	ELE55BLT1C
E	2" x 8" Schroeder Bellows Cylinder	CY2X8CY
	Ross Grease Bolt and nut	BR1X 3-1/2
	Ross Gear Plate Bushing	8 INCH GP Bushing

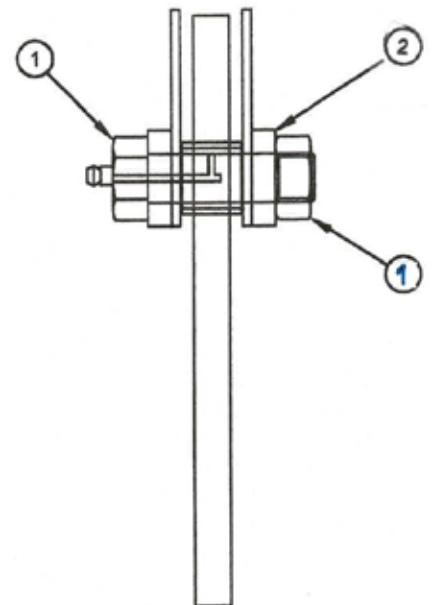
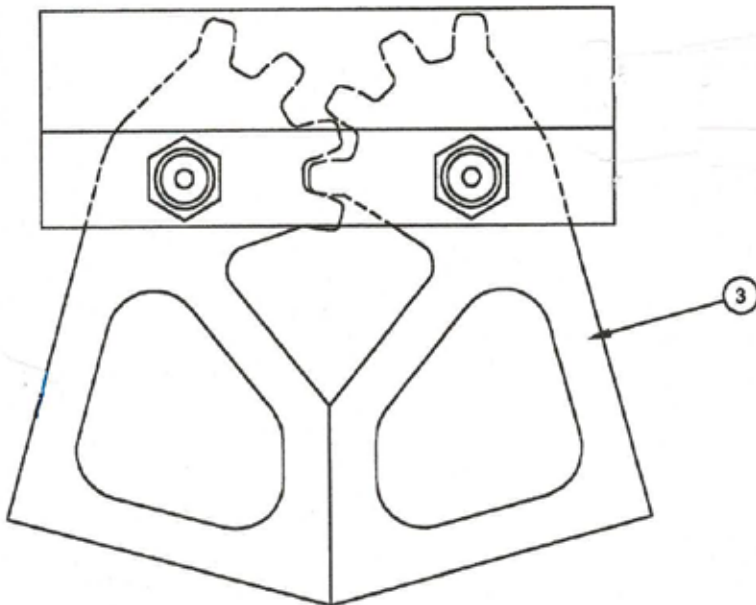

Discharge Hose

Description	Part #
10" Gum Rubber Boot	PGT-10
12" Gum Rubber Boot	PGT-12
16" Gum Rubber Boot	PGT-16
18" Gum Rubber Boot	PGT-18
20" Gum Rubber Boot	PGT-20
22" Gum Rubber Boot	PGT-22
24" Gum Rubber Boot	PGT-24
25" Gum Rubber Boot	PGT-25
6" Gum Rubber Boot	PGT-6
6 ^{3/4} " Gum Rubber Boot	PGT-6.75
8" Gum Rubber Boot	PGT-8
9" Gum Rubber Boot	PGT-9



Square Vinyl Flume

We also build custom and funnel Boot's.
Consult factory for more information.



Water

Seamed Gum Rubber



Taper Available



Name	Description	Part #
Flume	11" X 11" X 12"	111112
Flume	11" X 11" X 24"	111124
Flume	11" X 11" X 36"	111136
Flume	14" X 14" X 12"	141412
Flume	14" X 14" X 24"	141424
Flume	14" X 14" X 36"	141436

Gum Rubber Boot



Vinyl Boot



Discharge Hose

Description	Part #
12" PVC Blue Discharge	VF1200
10" PVC Discharge Hose	VF1000
2" Blue Discharge Hose	537-555-064
3" Blue Discharge Hose	537-555-107
4" Blue Discharge Hose	537-555-123

110 VAC Coil Assemblies - SMC

Standard 4-way air control valve on Bandit / Rustler / etc. plants. These valves are mounted in banks on a manifold type sub base. Two types of valves are used: (a) Two position, single solenoid valves control fill gates and the water system; and (b) Three position, double solenoid valves are used on the batcher discharge gates to provide "inching" control.

DESCRIPTION	TRB #:	SMC#	
Two Position, Four-way, Single Solenoid Type (3/4" body family)	55-76480	VANVFS5110-3DZA	 <p>TRB# 55-76480</p>
Repair Kit:	PS001424	KT-VFS5110	
Pilot. valve assy:	PS001423	SF4-3FA-30	
Inching Three Position, Four-way, CLOSED CENTER, Double Solenoid Type (3/4" body family)	55-76479	VANVFR5310-3DZA	 <p>TRB# 55-76479</p>
Repair Kit:	PS001425	KT-VFR5300	
Pilot valve assy:	PS001109	SF4-3FA-70	
Manifold Type Sub-Base (stacking type), 1/2" NPT ports in end of manifold	55-76484	MBF5710-04-1	 <p>TRB# 55-76484</p>
Sub-Base End-Plate Kit (for SMC Sub-Bases)	55-76485	MEF573LR-06-01	 <p>TRB# 55-76485</p>
Three Position, Four-way, OPEN CENTER, Double Solenoid Type (3/4" body family), NON-Inching (Used on 1248 swing-chute with transit-mix discharge option)	55-76539	VFS5410-3DZA	

2 WAY DIRECTIONAL CONTROL VALVES

110 VAC Coil Assemblies - ASCO

DESCRIPTION	TRB #:	ASCO#	BWD PT#:	
3/8" 2-way, pilot operated. Used for aeration and vibrator actuation	55-77236	8210G93	1275001008	 <p style="color: red; font-weight: bold;">TRB# 55-77236</p>
Repair Kit:	55-77820	302372		
Coil:	55-77051	238610-032-D		
3/4" 2-way, pilot operated Used for aeration and vibrator actuation	55-76457	8210G95	1275000532	 <p style="color: red; font-weight: bold;">TRB# 55-76457</p>
Repair Kit:	55-77821	302276		
Coil:	55-77051	238610-032-D		
1 1/4" 2-way, pilot operated. Used for trim water on 1248's and similar applications.	55-47647	8210G8		
Repair Kit:	55-77840	302280		
Coil:	55-77053	238210-032-D		
1 1/2" 2-way, pilot operated. Used for aeration actuation in systems with low pressure-high volume aerator pumps.	55-77839	8210G22	1275001368	 <p style="color: red; font-weight: bold;">TRB# 55-47647</p>
Repair Kit:	55-77822	302284		
Coil:	55-77053	238210-032-D		
Pulse-Jet Valve 1", 2-way, pilot controlled Pulse-Jet valve for 1, 3, & 6 CP, and , 12, 16, 24, 32, and 40 CPV Central Dust Collectors	55-76609	8353G41	1275000392	 <p style="color: red; font-weight: bold;">TRB# 55-76609</p>
Repair Kit:	55-77823	316563		
Coil:	55-77053	238210-032-D		
 <p style="color: red; font-weight: bold;">TRB# 55-77823 Repair Kit</p>				
Four-way, Two Position, Single Solenoid Type (1/8" body, 1/4" ports, NAMUR Interface, for water butterfly actuators)	55-76925	551-00-106	1275000798	 <p style="color: red; font-weight: bold;">TRB# 55-76925</p>
Repair Kit (Spool & seal kit):	55-77824	K-1000-00		
Repair Kit (Pilot seal kit):	55-77825	978-00-519		

2 Way Directional Control Valves

4 WAY DIRECTIONAL CONTROL VALVES 110 VAC Coil Assemblies - PARKER / SCHRADER BELLOWS





NOTE: The L705 two position and L695 three position valves are complete stand-alone valve assemblies. The L675 two position and L665 three position valves require a separate sub-base.

DESCRIPTION	TRB #:	P/SB#	
Two Position, Four-way, Single Solenoid type with integral sub-base (1/2" ports) Replaces L645-39-102 Repair Kit: Shock Pad:	55-47674 55-73067 55-74143	L705-49-102-53 K352 124 K983 002	 <p style="color: red; font-weight: bold; font-size: small;">TRB# 55-47674</p>
 <p style="color: red; font-weight: bold; font-size: small;">TRB# 55-73067 Repair Kit</p>			
Inching, Three Position, Four-way, Double Solenoid Type with integral sub-base (1/2" ports) Repair Kit: Shock Pad:	55-77319 55-89747 55-77827	L695-49-211-53 K352 126 K983 004	 <p style="color: red; font-weight: bold; font-size: small;">TRB# 55-77319</p>
 <p style="color: red; font-weight: bold; font-size: small;">TRB# 55-89747 Repair Kit</p>			
Two Position, Four-way, Single Solenoid Type with separate sub-base (3/8" body family) Repair Kit: Shock Pad:	55-76767 55-73067 55-74143	VAL6753910253 VAK352-124 VAK983-002	 <p style="color: red; font-weight: bold; font-size: small;">TRB# 55-76767</p>
 <p style="color: red; font-weight: bold; font-size: small;">TRB# 55-76767 Repair Kit</p>			
Inching, Three Position, Four-way, Double Solenoid Type with separate sub-base (3/8" body family) Repair Kit: Shock Pad:	55-76933 55-89747 55-77827	VAL6653921153 VAK352-126 VAK983-004	 <p style="color: red; font-weight: bold; font-size: small;">TRB# 55-76933</p>
 <p style="color: red; font-weight: bold; font-size: small;">TRB# 55-76933 Repair Kit</p>			
Single Station Sub-Base, 1/2" ports (stand alone, for L665 & L675 series valves)	55-77320	VAK022-091	 <p style="color: red; font-weight: bold; font-size: small;">TRB# 55-77320</p>

4 WAY DIRECTIONAL CONTROL VALVES

110 VAC Coil Assemblies - PARKER / SCHRADER BELLOWS

NOTE: The L705 two position and L695 three position valves are complete stand-alone valve assemblies. The L675 two position and L665 three position valves require a separate sub-base.

DESCRIPTION	TRB #:	P/SB#	
Manifold Type Sub-Base, 1/2" ports (for L665 & L675 series valves)	55-76768	K142-231	 <p style="text-align: center; color: red; font-weight: bold;">TRB# 55-76768</p>
Two Position, Four-way, Single Solenoid Type with integral sub-base (1/4" ports)	55-47682	L485-29-102-53	 <p style="text-align: center; color: red; font-weight: bold;">TRB# 55-47682</p>
Repair Kit:	55-47677	K352 150	
Shock Pad:	55-77826	K983 001	
 <p style="text-align: center; color: red; font-weight: bold;">TRB# 55-47677 Repair Kit</p>			
Two Position, Four-way, Single Solenoid Type with integral sub-base (3/8" ports)	55-76840	VAL7053910253	 <p style="text-align: center; color: red; font-weight: bold;">TRB# 55-76840</p>
Repair Kit:	55-73067	VAK352-124	
Shock Pad:	55-74143	VAK983-002	
 <p style="text-align: center; color: red; font-weight: bold;">TRB# 55-73067 Repair Kit</p>			
Inching, Three Position, Four-way, Double Solenoid Type with integral sub-base (3/8" ports)	55-47707	VAL6953921153	 <p style="text-align: center; color: red; font-weight: bold;">TRB# 55-47707</p>
Repair Kit:	55-89747	VAK352-126	
Shock Pad:	55-77827	VAK983-002	
 <p style="text-align: center; color: red; font-weight: bold;">TRB# 55-89747 Repair Kit</p>			

4 Way Solenoid Valves

TROUGHING IDLER ASSEMBLIES - INDIVIDUAL ROLLS FOR ROSS

Individual rolls come with bearings mounted; no pins or mounting brackets are included.

DESCRIPTION	TRB #:
4" x 8 1/2" Roll Fits Ross 24" - 3 required Fits Ross 30" - 2 required PLUS 1 14-1/2" roll	NA Replace Idler Assy CO4X8.5TR
4" x 12 1/2" Roll For Ross 36" equal length	NA Replace Idler Assy CO4X12.5
4" x 14 1/2" Roll Center Roll for Ross 30"	NA Replace Idler Assy CO4X14.5
4" x 16 1/2" Roll Fits Ross 48" x 35" equal length	NA Replace Idler Assy CO4X16.5

HARDWARE - COMMON TO ALL ROSS IDLER ASSEMBLIES

DESCRIPTION	TRB #:
Standard Roll Bearing Used on all Ross Design Rolls (Troughing, Flat, Return, & Impact)	55-76927 M15-103B TRB# 55-76927 
Center Mounting Shaft Double-ended shaft used to mount inboard ends of troughing rolls, and both ends of center rolls.	55-76862 2CS2-5/8 TRB# 55-76862 
End Mounting Shaft Single-ended shaft used to mount outboard ends of troughing rolls, and all Flat Idlers and Return Idlers.	004002339003 1CS2.5 TRB# 004002339003 
Return & Flat Idler Mount "Pillow Block" style mounting block for flat and return idlers, accepts End Mounting Shafts above.	44-314-01612-01 RRB102 1-1/2" DROP TRB# PS001533 
Drop Hanger Brackets, 1 1/2"	PS001533 TRB# 55-77363 
Drop Hanger Brackets, 4 1/2"	55-77363 RRB104 4-1/2' DROP

WAM® BUTTERFLIES

Nomenclature:

V1FS (size, metric/Std) Single flanged body with beaded extension on output side to receive a shroud, with cast iron disc.

V2FS (size) G - Double Flanged body, cast iron disc.

Size conversions:	100mm = 3.94" = 4" nominal size
	150mm = 5.90" = 6" nominal size
	200mm = 7.87" = 8" nominal size (8 3/4" boot ID)
	250mm = 9.84" = 10" nominal size (10 3/4" boot ID)
	300mm = 11.81" = 12" nominal size (12 3/4" boot ID)
	350mm = 13.78" = 14" nominal size
	400mm = 15.75" = 16" nominal size

The black seal material is superior when using the butterfly for powder applications. The WAM butterflies are for powder only, they will not hold water.

DESCRIPTION	TRB #:	
Thread adapter for all WAM Actuators (5M male to 1/8" MNPT)	55-76616	 <p style="color: red; font-weight: bold;">TRB# 55-76616</p>
CP 101 Actuator, for 8" - 12" Butterflies (BWD PT#: 1257501091)	55-73866	 <p style="color: red; font-weight: bold;">TRB# 55-73866</p>
CP 125 Actuator, for 14" & 16" Butterflies	55-77814	 <p style="color: red; font-weight: bold;">TRB# 55-77814</p>
Adapter - allows use of CP125 actuator on 8" Butterfly	55-78297	 <p style="color: red; font-weight: bold;">TRB# 55-73707</p>
M22 Limit Switch, fits all actuators (BWD PT#: 4834100473)	55-73707	 <p style="color: red; font-weight: bold;">TRB# 55-73709</p>
Hexagonal Bushing (pivot bushings, 2 required per butterfly, fits all sizes)	55-73709	 <p style="color: red; font-weight: bold;">TRB# 55-76434</p>
Disc seal for 6" WAM Butterfly	PS001049	 <p style="color: red; font-weight: bold;">TRB# 55-76974</p>
8" WAM Butterfly, with CP 101 Actuator, and M22 Limit Switch	55-76434	
8" WAM Butterfly ONLY (BWD PT#: 3726000471)	55-76974	

WAM Butterfly Valves

WAM® BUTTERFLIES (continued)

DESCRIPTION	TRB #:	
Disc Seal for 8" WAM Butterfly (BWD PT#: 3798200671)	55-77141	
Mounting Flange for 8" WAM Butterfly	55-10573-4008-11	
10" WAM Single Flange Butterfly ONLY	55-73864	
10" WAM Single Flange Butterfly with Actuator & Limit Switch	55-73175	
10" WAM Double Flange Butterfly ONLY	55-73865	
Disc Seal for 10" WAM Butterfly	55-73708	
Mounting Flange for 10" WAM Butterfly (BWD PT#: 0100009902759)	55-10073-1269-01	
12" WAM Single Flange Butterfly ONLY	55-77069	
12" WAM Double Flange Butterfly ONLY	55-77816	
12" WAM Single Flange Butterfly with Actuator & Limit Switch	55-79214	
12" WAM Double Flange Butterfly with Actuator & Limit Switch	55-76435	
Disc Seal for 12" WAM Butterfly	55-77809	
14" WAM Single Flange Butterfly ONLY	55-77817	

JOHNSON 12 YD³ DRUM POLY LINERS

DESCRIPTION	TRB #:	QTY:
Drum Liner Kit includes items #1 - #13:	55-60566-44921	
Front Cone Liner #1	55-10566-44921	4
Front Cone Liner #2	55-10566-44922	4
Girth Liner #3	55-10566-44923	4
Girth Liner #4	55-10566-44924	4
Rear Cone Liner #5	55-10566-44925	4
Rear Cone Liner #6	55-10566-44926	4
Back Cone Liner #7	55-10566-44927	8
Reinforcing Collar Liner #8	55-10566-44928	4
Spindle Cap Edge Liner #9	55-10566-44929	1
Spindle Cap Edge Liner #10	55-10566-449210	1
Spindle Ring Liner #11	55-10566-449211	1
Spindle Cap Liner #12	55-10566-449212	1
Blade Face Liner #13	55-10566-449213	4

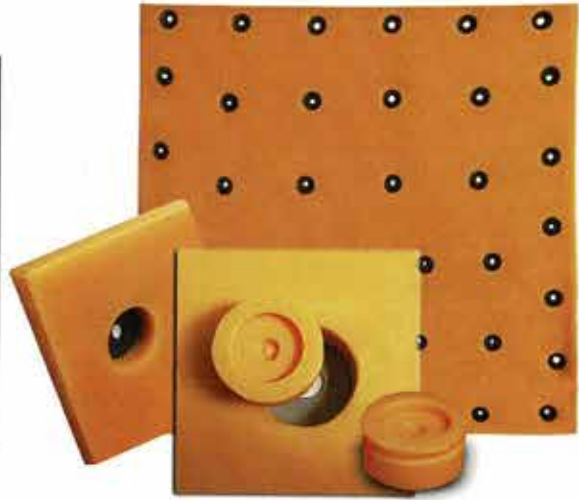
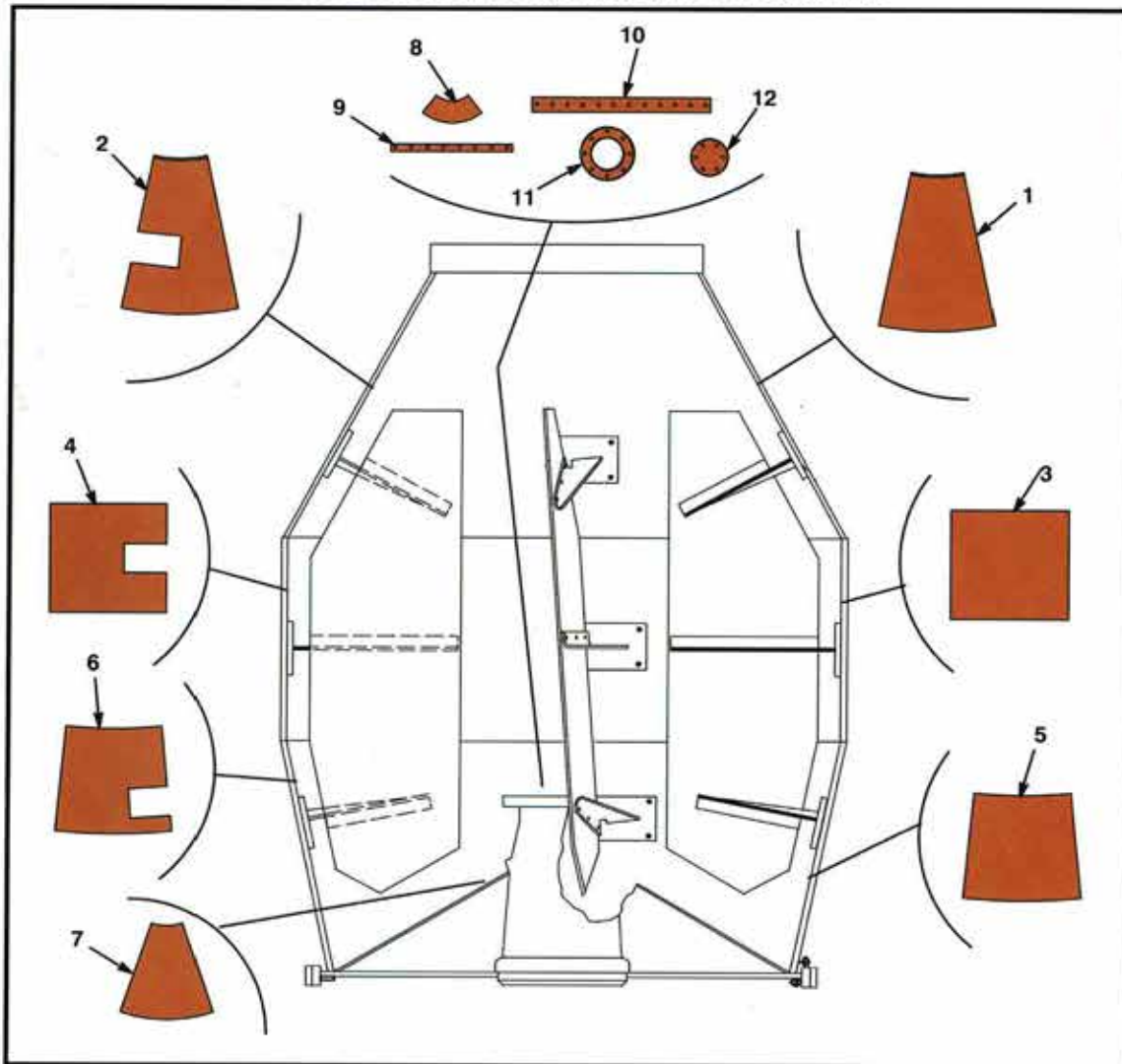

ILLUSTRATION MAY VARY FROM YOUR MACHINE





Johnson 12 YD Drum Poly Liners

ROSS MIXER POLY LINERS FOR: 8, 10, 12 YD³ ROSS TILT MIXERS

Ross Mixer Poly Liners

DESCRIPTION	TRB #:	QTY:	
12 YD Liner Kit includes:	44-407-19320-A1		
Nose Cone Liner	44-407-19320-01	8	
12 YD Belly Band Liner	44-407-19320-02	8	
Rear Cone Liner	44-407-19320-03	8	
Hub Cone Liner	44-407-19320-04	8	
Hub Cover Liner	44-407-19320-05	1	
Hub Cap Liner (round)	44-407-19320-06	1	
Sikaflex Adhesive	55-79257	36	
Rubber Seal for Discharge Hood	55-64309-40071		
Rubber <u>Only</u>	55-14309-4007-01		
Seal Ring for 1" Poly Liners	44-404-16257		
8 YD Belly Band Liner	55-77804	8	
10 YD Belly Band Liner	55-77341	8	
8 YD Blade Liner	55-77805	4	
10 YD Blade Liner	55-77342	4	
12 YD Blade Liner Kit includes 4 each of:	44-407-18979-A1	1	
Face Liner	55-78577	4	
Tip Liner	55-78578	4	
Tip Liner	55-78579	4	
Cone and Chute Liners <i>(see diagram at right):</i>			
Spill chute polyliner #1	55-79088		
Spill chute polyliner #2	55-79089		
Spill chute polyliner #3	55-79090		
Spill cone polyliner #4	55-78520		

JOHNSON MIXER DRUMS

DESCRIPTION	TRB #:	
Johnson Style Concrete Plant Mixer Drum (Ring Gear included)	55-60566-44663	 <p>TRB# 55-60566-44663 JOHNSON STYLE DRUM</p>
Forged Ring Gear for Johnson Style Drum	55-10451-42393	 <p>TRB# 55-10451-42393</p>

ROSS MIXER DRUMS

DESCRIPTION	TRB #:	
Ross Style Concrete Plant Mixer Drum (Ring Gear included)	44-406-19166-A1	 <p>TRB# 44-406-19166-A1 ROSS STYLE DRUM</p>
Ring Gear for Ross Style Drum	44-404-12613	

JOHNSON MIXER HYDRAULIC POWER UNIT

DESCRIPTION	TRB #:	DESCRIPTION	TRB #:
40HP HYDRAULIC POWER UNIT	55-76651	Self Erect Valve	55-78294
Complete Directional Valve	55-PS002109	Emergency Tilt Valve	PS001797
Coil	55-76586	Handle (Lever) Assy	PS001885
Pilot Valve	55-PS001385	Handle (Lever) Only	PS001886
Flow Control	55-76095	Suction Strainer	320008060000
Body Valve (<i>serial # req'd</i>)	CALL FOR PN	Relief Valve	55-77062
Cartridge	PS002124	Amplifier Card**	55-77446
Flow Control	55-PS002123	Dump Control Valve	55-77983
Bolt Kit	55-78295	1/2 Coupling	PS001242
Sun Dump Valve**	55-78329	Coupling insert	PS001244
Solenoid & Coil	PS000984	1/2 Coupling	PS001245
Coil Only	PS000985	Clean Out Gasket	PS001753
Vane Pump	55-77060	Top Gasket	PS001752
Return Filter	55-77061	Motor, 40HP, 1800RPM, 230/460/60/3	CALL FOR PN
Filter Head Assy	55-PS002344	Motor, 2HP, 1800RPM, 115/230/60/1	PS001916
Proportional Valve**	55-78330	Pressure Gauge (0-3000 PSI)	55-76760
Coil	PS001909	Secondary Pump, gear	55-77977
		Sight Level & Temperature Gauge	PS001656

** For Variable Speed Units Only

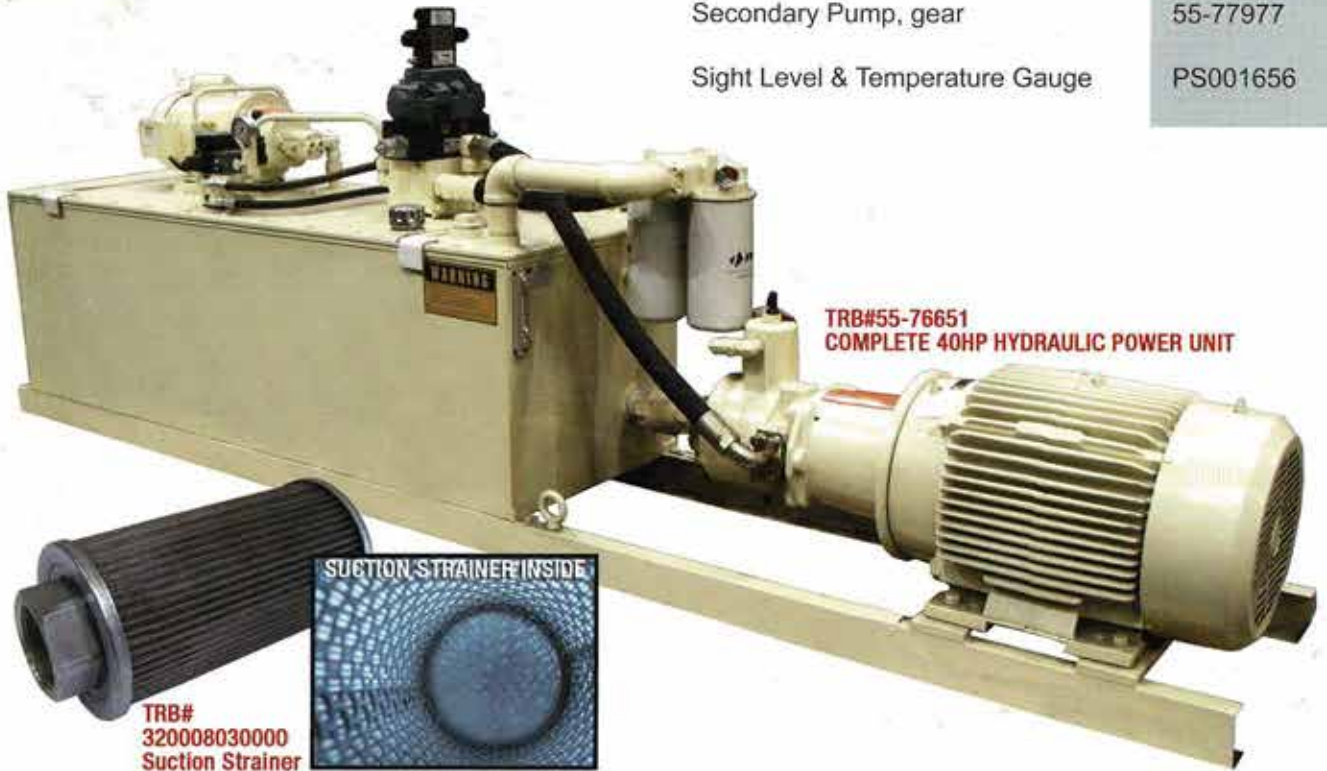



TRB# PS001916
Motor 2HP



TRB# PS001885 Handle Assy
TRB# PS001797 Emergency Tilt Valve
TRB# 55-76760 Pressure Gauge

TRB# 55-78294 Self Erect Valve



TRB#'s:
55-76586 Coil
PS001385 Pilot Valve
55-76095 Flow Control
CALL - SERIAL# REQ'D Body Valve

PS002124 Cartridge
55-PS002123 Flow Control

TRB# 55-PS002109 COMPLETE DIRECTIONAL VALVE



TRB# 55-PS002344 Filter Head Assy



TRB# 55-77061



TRB# 55-PS002344 Filter Head Assy

TRB# 55-77061 Return Filter



TRB# 55-77060 Vane Pump

Coupling



TRB#'s PS001242, PS001244, PS001245 Coupling

Motor 40HP

Johnson Mixer Components

ROSS MIXER COMPONENTS PADDLES & BOLTS

DESCRIPTION	TRB #:	CHAMP PT#:	BWD PT#:
10 YD³ (7.64 M³) PADDLES & LEGS Includes complete bolt kit (noted below) and 12 support legs total:	55-64404-40011	64404-40011	01000040402243
Four paddles: 3 legs per paddle	55-14404-4001-W1		0150040402243
- front support, 4 required	55-14404-4001-W2		0160040402243
- middle support, 4 required	55-14404-4001-W3		0170040402243
- rear support, 4 required	55-14404-4001-W4		0180040402243
PADDLES ONLY	55-14404-4001-W1	64404-40012	0150040402243
12 YD³ (9.1 M³) PADDLES & LEGS Includes complete bolt kit (noted below) and 12 support legs total:	44-406-05689-A1	64406 40021	01000040605689
Four paddles: 3 legs per paddle	44-406-05689-W1		
- front support, 4 required	44-406-05689-W2		
- middle support, 4 required	44-406-05689-W3		
- rear support, 4 required	44-406-05689-W4		
PADDLES ONLY (SINGLE)	44-406-05689-W1	64406-40022	0150040605689
BOLT KIT (same for 10 YD ³ & 12 YD ³ mixers) Includes 32 (thirty-two) 3/4" x 2 1/2" grade 5 bolts with nuts and lock washers; and 48 (forty-eight) 1" x 4" grade 5 bolts with nuts and lock washers.			
QTY	ITEM		
32	3/4" x 2 1/2" grade 5 bolts	000A00169000	
32	3/4" nuts	000A03494000	
32	3/4" flat washers	000A00299000	
32	3/4" lock washers	000A00311000	
48	1" x 4" grade 5 bolts	000A00213000	
48	1" nuts	000A00277000	
48	1" flat washers	000A00301000	
48	1" lock washers	000A00313000	



TRB# 44-406-05689-W1









TRB# 000A00301000

TRB# 000A00313000

TRB# 000A00311000

ROSS MIXER COMPONENTS
BEARINGS & SEALS

DESCRIPTION	TRB #:	
Front Bearing, Cone (Nose Cone End)	55-77419	
Front Bearing, Cup (Nose Cone End)	55-77418	
Rear Bearing, Cone	55-77420	
Rear Bearing, Cup	55-77421	
Wear Ring For Rear Seal	55-77413	
Rear Seal, Single Piece NOT split	55-78194	
Rear Seal, Split Seal, <i>Can be installed in the field.</i>	55-77329	
Glue (Rear Split Seal) <i>Must use with Split Seal.</i> <i>One tube should be sufficient for one split seal.</i>	55-79113	

DRIVE COMPONENTS

DESCRIPTION	TRB #:	
12 YD³ MIXER 60 HP		
Motor, 60 HP, 1800 TEFC, 364T Frame	316000520550	
Gear Reducer, Modified for tilting applications	55-78433	
Gear Breather DCR6	55-78434	
Gear Scoop, G-Grid Line & Scoop	55-78435	
GEARS & MISCELLANEOUS		
18 Tooth Pinion Gear	55-77172	
Ring Gear (Bull Gear) <i>NOTE* 12 week lead time if not in stock</i>	44-404-12613	
INSTALLATION TOOL and CLAMPS REQUIRED for FIELD INSTALLATION (No charge if returned)		
Ring Gear Installation Tool	44-407-19144-A1	TRB# 55-78435
Ring Gear Clamps (requires qty 10)	44-407-19145-A1	
		TRB# 55-77172

HYDRAULIC CYLINDERS & COMPONENTS

FOR: 8, 10, 12 YD³ ROSS TILT MIXERS

DESCRIPTION	TRB #:	BWD PT#:
Tilt Cylinder 4" x 48" with 2- 3/4" rod	55-77096	12510000953
		 <p style="text-align: center; color: red;">TRB# 55-77096</p>
Rod End with spherical bearing for 4" x 48" Tilt Cylinder	44-406-15640-10	0110040615640
		 <p style="text-align: center; color: red;">TRB# 44-406-15640-10</p>
Spherical Bearing (Rod End)	55-78466	
		 <p style="text-align: center; color: red;">TRB# 55-78466</p>
Rod End Cylinder Pin for 4" x 48" Tilt Cylinder	44-404-04316-W2	0119040404316
		 <p style="text-align: center; color: red;">TRB# 44-404-04316-W2</p>
Clevis Mount (lower cylinder mount) for 4" x 48" Tilt Cylinder	44-406-15640-A2	0130040615640
		 <p style="text-align: center; color: red;">TRB# 44-406-15640-A2</p>
Spherical Bearing (Clevis Mount)	55-78465	
		 <p style="text-align: center; color: red;">TRB# 55-78465</p>
Lower Cylinder Pin for 4" x 48" Tilt Cylinder	55-78215	
		 <p style="text-align: center; color: red;">TRB# 44-404-04316-W1</p>
Main Pivot Pin 4" OD x 8 1/2" Long	44-404-04316-W1	0118040404316
		 <p style="text-align: center; color: red;">TRB# 44-404-04316-W1</p>
Main Pivot Pin Bushing Receiver WITH Bushing Installed	44-404-03128-A1	0108040403128 & 0109040403128
<i>NOTE: This item is sold as one unit only and consists of TRB part 44-404-03128-008 sleeve, and 44-404-03128-09 bronze bushing. Neither can be sold separately.</i>		 <p style="text-align: center; color: red;">TRB# 44-404-03128-A1</p>

Ross Hydraulic Cylinders & Components

Turn Head 1" Ceramic Liner

(Complete Set Liner ML-St-ooth03K-g83)
1" Ceramic for Standard Turn Head

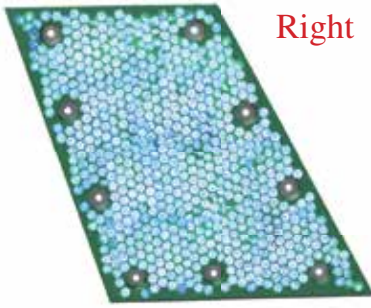

Right

ML-St-ooth 03ARK-g83

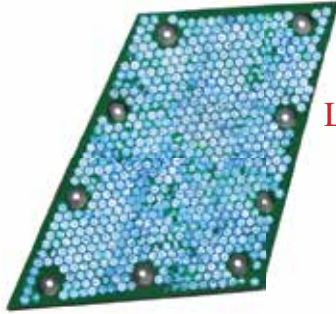

Left

ML-St-ooth 03ALK-g83

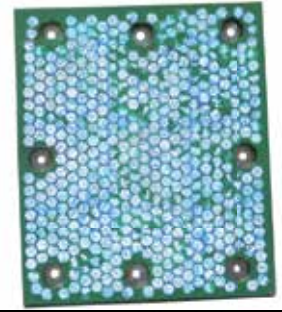

ML-St-ooth 03DK-g83

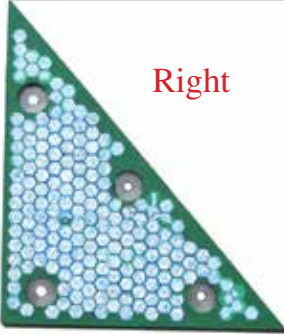

Right

ML-St-ooth 03BRK-g83

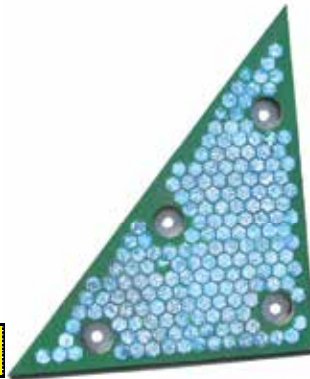

Left

ML-St-ooth 03BLK-g83

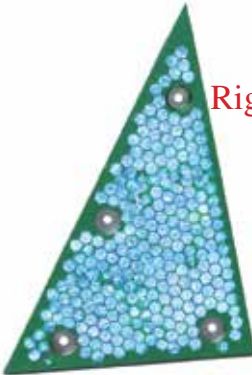

Right

ML-St-ooth 03CRK-g83

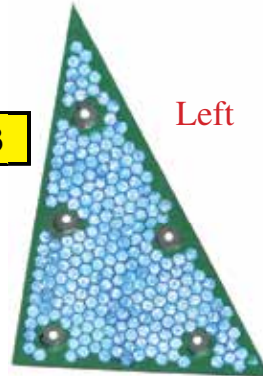

Left

ML-St-ooth 03CLK-g83

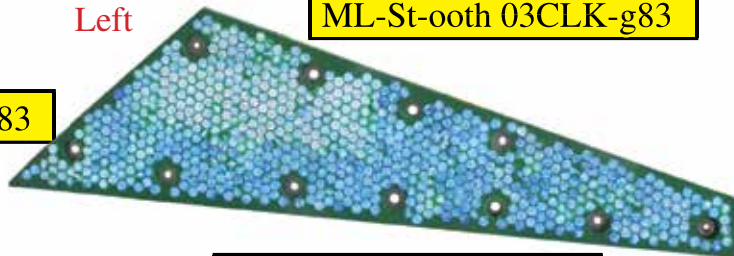

Left

ML-St-ooth 03FLK-g83

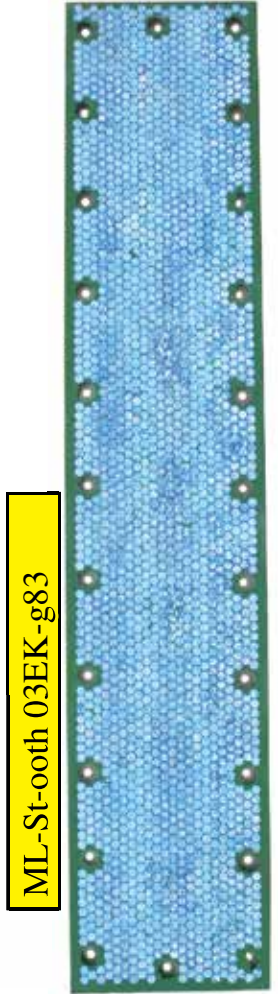

ML-St-ooth 03EK-g83

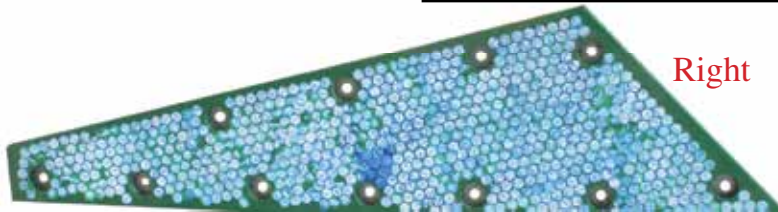

Right

ML-St-ooth 03FRK-g83



Plugs

4 Compartment Stephens AR Liner for Aggregate Bin

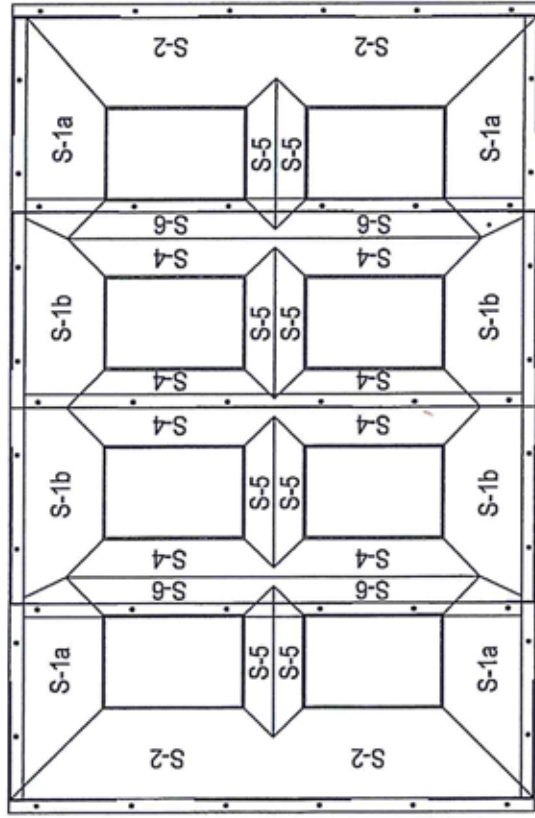

TOP VIEW

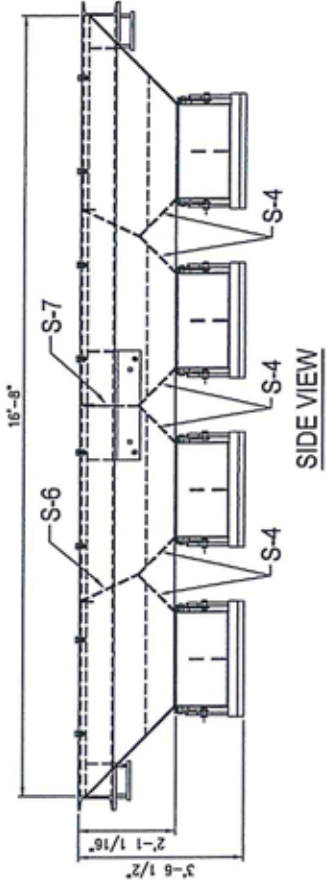

SIDE VIEW

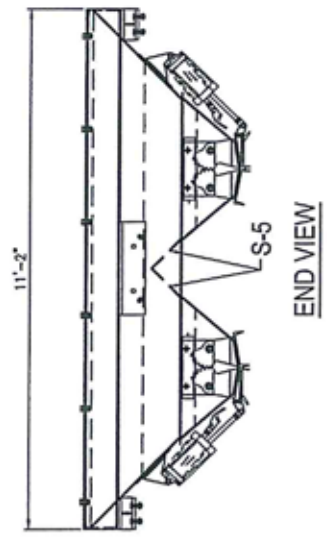

END VIEW

1/4" METAL: WELD-IN (A/R) ABRASIVE RESISTANT LINERS ON SLOPING SIDES					
I.D.	DESCRIPTION	QTY.	WEIGHT	PART NUMBER	1/4" A/R (WELD-IN)
S-1a	1/4" A/R METAL (WELD-IN)	4	337	SBAR1A080-00201	1/4" A/R (WELD-IN)
S-1b	1/4" A/R METAL (WELD-IN)	4	337	SBAR1B080-00201	1/4" A/R (WELD-IN)
S-2	1/4" A/R METAL (WELD-IN)	4	490	SBAR2A080-00201	1/4" A/R (WELD-IN)
S-4	1/4" A/R METAL (WELD-IN)	12	490	SBAR4A080-00201	1/4" A/R (WELD-IN)
S-5	1/4" A/R METAL (WELD-IN)	8	164	SBAR5A080-00201	1/4" A/R (WELD-IN)
S-6	1/4" A/R METAL (WELD-IN)	4	145	SBAR6A080-00201	1/4" A/R (WELD-IN)
S-7	1/4" A/R METAL (WELD-IN)	2	123	SBAR7A080-00201	1/4" A/R (WELD-IN)
TOTAL WEIGHT COMPLETE A/R LINERS					2186#

1/4" METAL: BOLT-IN (A/R) ABRASIVE RESISTANT LINERS ON SLOPING SIDES					
I.D.	DESCRIPTION	QTY.	WEIGHT	PART NUMBER	1/4" A/R (BOLT-IN)
S-1a	1/4" A/R METAL (BOLT-IN)	4	337	SBAR1A080-00202	1/4" A/R (BOLT-IN)
S-1b	1/4" A/R METAL (BOLT-IN)	4	337	SBAR1B080-00202	1/4" A/R (BOLT-IN)
S-2	1/4" A/R METAL (BOLT-IN)	4	490	SBAR2A080-00202	1/4" A/R (BOLT-IN)
S-4	1/4" A/R METAL (BOLT-IN)	12	490	SBAR4A080-00202	1/4" A/R (BOLT-IN)
S-5	1/4" A/R METAL (BOLT-IN)	8	164	SBAR5A080-00202	1/4" A/R (BOLT-IN)
S-6	1/4" A/R METAL (BOLT-IN)	4	145	SBAR6A080-00202	1/4" A/R (BOLT-IN)
S-7	1/4" A/R METAL (BOLT-IN)	2	123	SBAR7A080-00202	1/4" A/R (BOLT-IN)
TOTAL WEIGHT COMPLETE A/R LINERS					2186#

STEPHENS TITAN: THOROUGHbred AND STALLION 4-COMPARTMENT AGG. BIN CONE A/R LINERS

DATE	10-18-2018	BY	ME
SCALE	AS SHOWN	APP. BY	ME
REVISION		DATE	
NO.		BY	
REV.		DATE	
Stephens TITAN 4-COMPARTMENT AGG. BIN CONE			
STEPHENS TITAN 4-COMPARTMENT AGG. BIN CONE		STEPHENS TITAN 4-COMPARTMENT AGG. BIN CONE	
1/4" A/R METAL (WELD-IN)		1/4" A/R METAL (WELD-IN)	
1/4" A/R METAL (BOLT-IN)		1/4" A/R METAL (BOLT-IN)	
1/4" A/R METAL (WELD-IN)		1/4" A/R METAL (WELD-IN)	
1/4" A/R METAL (BOLT-IN)		1/4" A/R METAL (BOLT-IN)	
1/4" A/R METAL (WELD-IN)		1/4" A/R METAL (WELD-IN)	
1/4" A/R METAL (BOLT-IN)		1/4" A/R METAL (BOLT-IN)	

1/4" METAL: WELD-IN (A/R) ABRASIVE RESISTANT LINERS ON SLOPING SIDES

I.D.	DESCRIPTION	QTY.	WEIGHT	PART NUMBER
S-1	1/4" A/R METAL (WELD-IN)	6	617	SBAR1A080-00101
S-2	1/4" A/R METAL (WELD-IN)	4	490	SBAR2A080-00101
S-4	1/4" A/R METAL (WELD-IN)	8	817	SBAR4A080-00101
S-5	1/4" A/R METAL (WELD-IN)	6	123	SBAR5A080-00101
TOTAL WEIGHT COMPLETE A/R LINERS				2047#

1/4" METAL: BOLT-IN (A/R) ABRASIVE RESISTANT LINERS ON SLOPING SIDES

I.D.	DESCRIPTION	QTY.	WEIGHT	PART NUMBER
S-1	1/4" A/R METAL (BOLT-IN)	6	617	SBAR1A080-00102
S-2	1/4" A/R METAL (BOLT-IN)	4	490	SBAR2A080-00102
S-4	1/4" A/R METAL (BOLT-IN)	8	817	SBAR4A080-00102
S-5	1/4" A/R METAL (BOLT-IN)	6	123	SBAR5A080-00102
TOTAL WEIGHT COMPLETE A/R LINERS				2047#

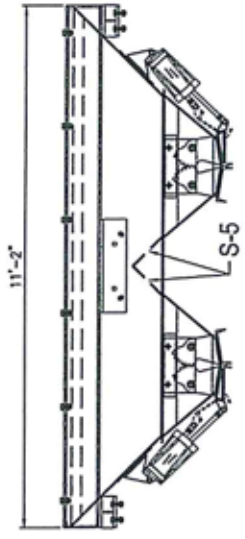
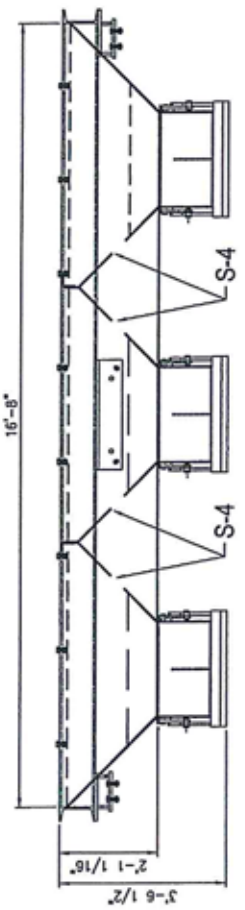
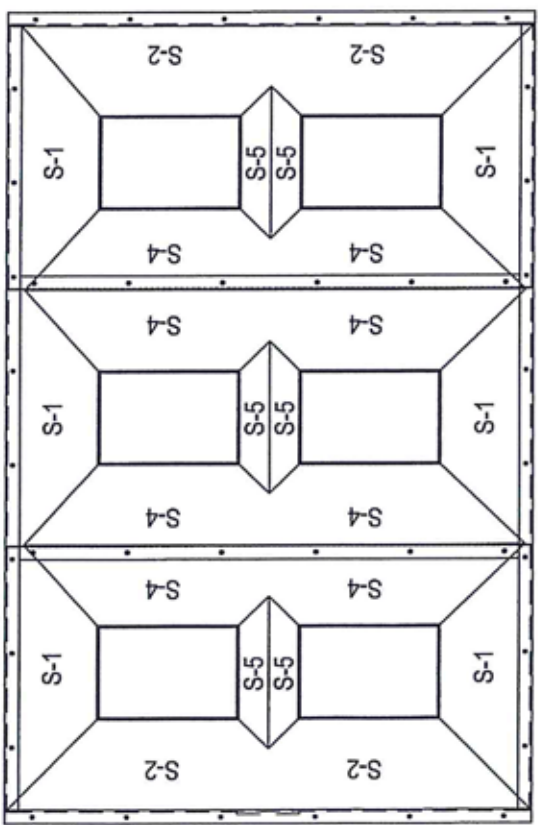

STEPHENS TITAN: THOROUGHBRED AND STALLION 3-COMPARTMENT AGG. BIN CONE A/R LINERS

REV	DATE	BY	CHK	DESCRIPTION
1	10-18-2018	STEPHENS	CMW	3-COMPARTMENT AGG. BIN CONE
2				
3				
4				
5				
6				
7				
8				
9				
10				
11				
12				
13				
14				
15				
16				
17				
18				
19				
20				
21				
22				
23				
24				
25				
26				
27				
28				
29				
30				
31				
32				
33				
34				
35				
36				
37				
38				
39				
40				
41				
42				
43				
44				
45				
46				
47				
48				
49				
50				
51				
52				
53				
54				
55				
56				
57				
58				
59				
60				
61				
62				
63				
64				
65				
66				
67				
68				
69				
70				
71				
72				
73				
74				
75				
76				
77				
78				
79				
80				
81				
82				
83				
84				
85				
86				
87				
88				
89				
90				
91				
92				
93				
94				
95				
96				
97				
98				
99				
100				

STEPHENS
DUNSTONVILLE, KY 40311

FOR THE 1/4" A/R AGG. BIN CONE LINERS WELD-IN A/R LINERS
FOR THE 1/4" A/R AGG. BIN CONE LINERS BOLT-IN A/R LINERS

DESIGN: 00101



CEMA B Flat Carrier Idlers

Flat Carrier Idlers

4" & 5" Rolls

Part Number	BW	A	C	G	4" WT	5" WT
B★-F-14	14	23	25	17 3/8	17	19
B★-F-16	16	25	27	19 3/8	18	20
B★-F-18	18	27	29	21 3/8	19	21
B★-F-20	20	29	31	23 3/8	20	23
B★-F-24	24	33	35	27 3/8	22	25
B★-F-30	30	39	41	33 3/8	25	29
B★-F-36	36	45	47	39 3/8	28	32
B★-F-42	42	51	53	45 3/8	31	36
B★-F-48	48	57	59	51 3/8	34	39

☆ = Roll Diameter

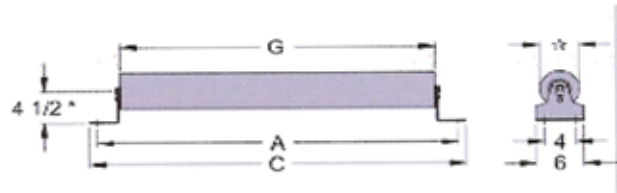

* 4 1/2" brackets are standard, 1 1/2" are available, add -1 behind part number.

Flat Rubber Disc Carrier Idlers

5" Rolls

Part Number	BW	A	C	G	WT
B5-FRD-14	14	23	25	16 1/4	27
B5-FRD-16	16	25	27	18 1/4	29
B5-FRD-18	18	27	29	20 1/4	31
B5-FRD-20	20	29	31	22 1/4	33
B5-FRD-24	24	33	35	26 1/4	36
B5-FRD-30	30	39	41	32 1/4	43
B5-FRD-36	36	45	47	38 1/4	50
B5-FRD-42	42	51	53	44 1/4	57
B5-FRD-48	48	57	59	50 1/4	63

4" diameter rolls are also available.

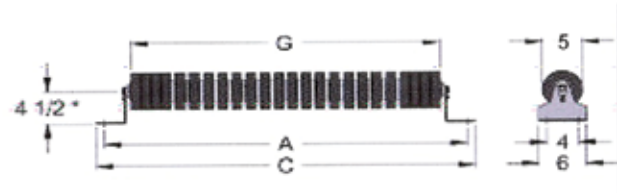

* 4 1/2" brackets are standard, 1 1/2" are available, add -1 behind part number.

Flat Self-Aligning Carrier Idlers

4" & 5" Rolls

Part Number	BW	A	C	G	4" WT	5" WT
B★-FSA-14	14	23	25	17 3/8	47	49
B★-FSA-16	16	25	27	19 3/8	49	52
B★-FSA-18	18	27	29	21 3/8	52	55
B★-FSA-20	20	29	31	23 3/8	55	57
B★-FSA-24	24	33	35	27 3/8	60	63
B★-FSA-30	30	39	41	33 3/8	68	72
B★-FSA-36	36	45	47	39 3/8	76	80
B★-FSA-42	42	51	53	45 3/8	84	89
B★-FSA-48	48	57	59	51 3/8	92	97

☆ = Roll Diameter

T = H + 3 11/16

M = 4 5/16

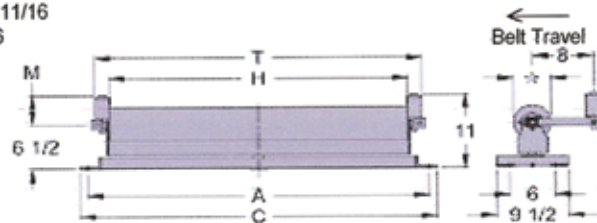

Channel Inset Flat Carrier Idlers

4" & 5" Rolls

Part Number	BW	A	D	G	4" WT	5" WT
B★-CIF-14	14	22	24	16 1/2	14	16
B★-CIF-16	16	24	26	18 1/2	15	17
B★-CIF-18	18	26	28	20 1/2	16	18
B★-CIF-20	20	28	30	22 1/2	17	19
B★-CIF-24	24	32	34	26 1/2	19	22
B★-CIF-30	30	38	40	32 1/2	22	26
B★-CIF-36	36	44	46	38 1/2	25	29
B★-CIF-42	42	50	52	44 1/2	27	33
B★-CIF-48	48	56	58	50 1/2	31	36

☆ = Roll Diameter

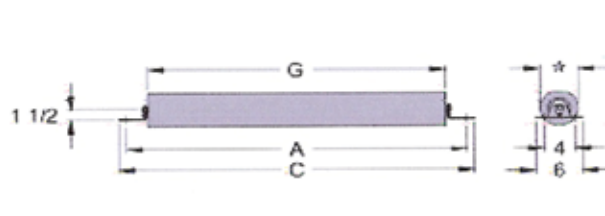

We also replace other Brand Rolls. Give us a call for more information.



CEMA B Troughing Idlers

20° Troughing Idlers

4" Rolls

Part Number	BW	A	B	C	D	E	G	H	K	WT
B4-20TE-14	14	23	6	25	8	9 1/16	5 7/16	16 15/16	7	25
B4-20TE-16	16	25	6	27	8	9 1/16	6 3/4	18 1/4	7	26
B4-20TE-18	18	27	6	29	8	9 7/16	6 3/4	20 11/16	7	28
B4-20TE-20	20	29	6	31	8	9 13/16	7 5/8	23 1/4	7	30
B4-20TE-24	24	33	6	35	8	10 1/4	8 15/16	26 15/16	7	33
B4-20TE-30	30	39	6	41	8	10 15/16	11 1/8	33 5/16	7	39
B4-20TE-36	36	45	6	47	8	11 11/16	13 1/4	39 7/16	7	44
B4-20TE-42	42	51	7 1/2	53 1/2	9 1/2	12 15/16	15 7/16	45 3/4	7 1/2	54
B4-20TE-48	48	57	7 1/2	59 1/2	9 1/2	13 11/16	17 5/8	52 1/16	7 1/2	60

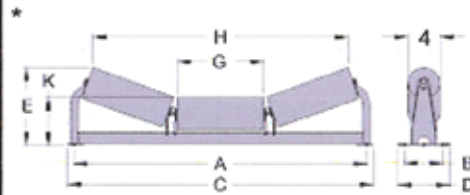

20° Troughing Idlers

5" Rolls

Part Number	BW	A	B	C	D	E	G	H	K	WT
B5-20TE-14	14	23	6	25	8	9 1/2	5 7/16	16 9/16	7 1/2	28
B5-20TE-16	16	25	6	27	8	9 1/2	6 3/4	17 7/8	7 1/2	29
B5-20TE-18	18	27	6	29	8	9 15/16	6 3/4	20 3/8	7 1/2	32
B5-20TE-20	20	29	6	31	8	10 1/4	7 5/8	22 7/8	7 1/2	34
B5-20TE-24	24	33	6	35	8	10 11/16	8 15/16	26 11/16	7 1/2	38
B5-20TE-30	30	39	6	41	8	11 7/16	11 1/8	32 15/16	7 1/2	43
B5-20TE-36	36	45	6	47	8	12 3/16	13 1/4	39 1/16	7 1/2	49
B5-20TE-42	42	51	7 1/2	53 1/2	9 1/2	13 7/16	15 7/16	45 3/8	8	60
B5-20TE-48	48	57	7 1/2	59 1/2	9 1/2	14 3/16	17 5/8	51 11/16	8	66

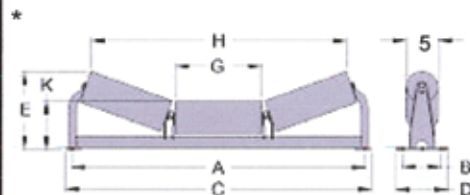

35° Troughing Idlers

4" Rolls

Part Number	BW	A	B	C	D	E	G	H	K	WT
B4-35TE-14	14	23	6	25	8	10 1/4	5 7/16	15 1/2	7	26
B4-35TE-16	16	25	6	27	8	10 1/4	6 3/4	16 4/5	7	27
B4-35TE-18	18	27	6	29	8	10 15/16	6 3/4	18 15/16	7	29
B4-35TE-20	20	29	6	31	8	11 1/2	7 5/8	21 1/4	7	31
B4-35TE-24	24	33	6	35	8	12 1/4	8 15/16	24 11/16	7	34
B4-35TE-30	30	39	6	41	8	13 1/2	11 1/8	30 1/2	7	40
B4-35TE-36	36	45	6	47	8	14 11/16	13 1/4	36 1/8	7	45
B4-35TE-42	42	51	7 1/2	53 1/2	9 1/2	16 7/16	15 7/16	41 7/8	7 1/2	56
B4-35TE-48	48	57	7 1/2	59 1/2	9 1/2	17 11/16	17 5/8	47 5/8	7 1/2	62

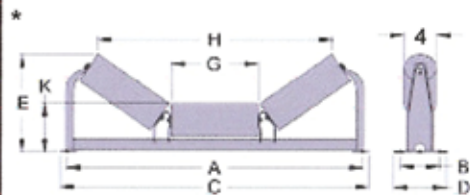

35° Troughing Idlers

5" Rolls

Part Number	BW	A	B	C	D	E	G	H	K	WT
B5-35TE-14	14	23	6	25	8	10 11/16	5 7/16	14 7/8	7 1/2	29
B5-35TE-16	16	25	6	27	8	10 11/16	6 3/4	16 1/4	7 1/2	30
B5-35TE-18	18	27	6	29	8	11 3/8	6 3/4	18 3/8	7 1/2	32
B5-35TE-20	20	29	6	31	8	11 15/16	7 5/8	20 11/16	7 1/2	35
B5-35TE-24	24	33	6	35	8	12 5/8	8 15/16	24 1/8	7 1/2	39
B5-35TE-30	30	39	6	41	8	13 15/16	11 1/8	29 7/8	7 1/2	45
B5-35TE-36	36	45	6	47	8	15 1/8	13 1/4	35 1/2	7 1/2	51
B5-35TE-42	42	51	7 1/2	53 1/2	9 1/2	16 7/8	15 7/16	41 1/4	8	62
B5-35TE-48	48	57	7 1/2	59 1/2	9 1/2	18 1/8	17 5/8	47 1/16	8	69

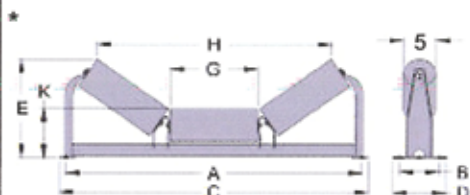

Head Pulleys

Description 3/8 HBG Lagging	Part #
12" X 26" Head Pulley	XPU1226PXT25
12" X 32" Head Pulley	XPU1232PXT25
14" X 26" Head Pulley	XPD1426PXT25
14" X 36" Head Pulley	XPD1436PXT30
16" X 26" Head Pulley	XPD1626PXT30
16" X 32" Head Pulley	XPD1632PXT30
18" X 26" Head Pulley	XPD1826PXT35
18" X 32" Head Pulley	XPD1832PXT
20" X 26" Head Pulley	XPD2026PXT35
20" X 32" Head Pulley	XPD2032PXT30
30" X 32" Head Pulley	XPD3032PXT

(Other Sizes also available).



No Lagging



With Lagging

Winged Tail Pulley

Description	Part #
10" X 26" Wing Pulley	XPW1026PXT
10" X 32" Wing Pulley	XPW1032PXT25
12" X 26" Wing Pulley	XPW1226PXT25
12" X 32" Wing Pulley	XPW1232PXT25
14" X 26" Wing Pulley	XPW1426PXT
14" X 32" Wing Pulley	XPW1432PXT
16" X 26" Wing Pulley	XPW1626PXT30
16" X 32" Wing Pulley	XPW1632PXT30
18" X 38" Wing Pulley	XPW1832PXT
20" X 32" Wing Pulley	XPW2032PXT

Winged Tail Pulley



Wing & Head Pulley SHAFTS

Note: Any size head or wing shafts are available. Please consult factory. Shaft's are TGP turned ground polished.

Scale Levers Systems

Description	Part #
7000 LB Cement Levers	Lever 7000
10000 LB Cement Levers	Lever 10000
36000 LB AGG Levers	Lever 36000
40000 LB AGG Levers	Lever 40000



Scale Levers

Blow Back Blower Components

Description	Part #
10HP 3500 RPM Motor 230/460 Volt	P21-S-3025
Roots Blower	33URAI
Inlet Filter 2 ^{1/2} W/Paper	EMF-25-060124
Check Valve 2"	5050
Static 0-200' Pressure Gauge	T8G-L
1" Weighted Relief Valve	13-214-06
Dodge PX60 Para-Flex-Ele	011106
Dodge Px60 I-L Flanges	010602
1310X1 ^{3/8} KW Dodge Bearing	119404
1310X3/4 KW Dodge Bearing	119394
Blow Back Pod	MP Blow Pod-01



Load Cells

Description	Part #
250 LB 100'	20210-250LB
500 LB 100'	20210-500LB
1000 LB 100'	20210-1K
1500 LB 100'	20210-1.5K
2000 LB 100'	20210-2K
3000 LB 100'	20210-3K
5000 LB 20'	20210-5K
10000 LB 20'	20210-10K
15000 LB 20'	20210-15K
20000 LB 20'	20210-20K
Summing Board/fiberglass-enclosed	SB-1



Digital Readouts

Description	Part #
Cardinal Readout	205A



Motors

Description	Part #
1/3 HP 1800 RPM 208/230/460 3PH	MOT1/31846056CW
1/2 HP 1725 RPM 1PH	T12-18-56CB
5 HP 1800 RPM 460 VOLT 184T	MOT518460184TW
10 HP 1200 RPM 460 VOLT 256T	MOT1012460256TW
15 HP 1800 RPM 575 VOLT 254T	MOT1518575254TW
20 HP 1800 RPM 460 VOLT 256T	MOT2018460256TW
25 HP 1800 RPM 460 VOLT 256T	MOT2518460256TW
30 HP 1800 RPM 460 VOLT 286T	MOT3018460286TW
40 HP 1800 RPM 480 VOLT 324T	MOT4018480324TW
50 HP 1800 RPM 575 VOLT 326T	MOT5018575326TW



**Please consult factor for various hp, rpm, voltages, and frame size needed.*



Reducer

Description	Part #
TA3203H25	903001
TA4207H27	904001
TA5215H25	905001

Other Sizes & Models Available

Remtron Radial Stacker Radio Remote

A Antenna	485-026
Remote	22TIOA-0808A+S/N
Snubbers	600052
Function Remote Manual Button Comp.	SP6F1324TELE



Wall Mount Panel Remote with Control Box



Tele-Radio



Description	Part #
4 Function Remote Parts Comp.	T60-04-STP
6 Function Remote Parts. Comp	T60-06STP

Description	Part #
4 Function Receiver Board	T60-RX-04DSL
6 Function Receiver Board	T60-RX-06DSL



Remote Complete with Manual Buttons

Tele-Radio



Description	Part #
4 Function Transmitter only	T60TX-04SRL
6 Function Transmitter only	T60TX-06SRL



Hand Held Remote

Description	Part #
4- Button Handheld Trans. Linear	DT-4B



AEC Remote

Description	Part #
4-Function Remote Parts Comp	MP4J-4-115 M

Silo

Letter	Description	Part#
A	Overfill Protection	OP KIT
B	Emergency Pop-Off Valves	POV 101A
C	Handles for Inspection Hatch & Vent Doors	381600000000
D	Safety Climbing Device	999999999997
E	Griffin Safety Silo Pop-Off	800-DSK
F	WAM Safety Pop-Off	VCP2731/V



Overfill Protection

Description	Part #
1 COMP 4" Silo Overfill Protection	8985641
1 COMP 5" Silo Overfill Protection	6467751
2 COMP 4" Silo Overfill Protection	6553342
2 COMP 5" Silo Overfill Protection	2564452
3 COMP 4" Silo Overfill Protection	6768843
3 COMP 5" Silo Overfill Protection	6583253
4 COMP 4" Silo Overfill Protection	6768844



Description	Part #
Silo Warning Horn System Asy	1589000
Silo Warning Horn System /2 Comp	1589002
Silo Warning Horn System 3 Comp	1589001

C&W Anti-Overfill

Description	Part#
Overfill Control Panel	SS130
4" Pinch Valve	PV4-WM
5" Pinch Valve	PV5-WM
1/4" (SB) Solenoid Valve	S0017
4" Gasket	GA000
5" Gasket	GA001



“MAC” Solenoid Valves

Letter	Description	Part #
	Single Solenoid	6313D611PM112DA
A	Base & Top	6313D611PM112DA
	Top Only	6313D000PM112DA
	Double Solenoid	
B	Base & Top	6333D611PM112DA
	Top Only	6333D000PM112DA
C	Aeration Solenoid	55B12PI112CA
D	Water Solenoid	912BPM112CA
	Double Solenoid	6300D-611-D
	Single Solenoid Base	6300D-611-S

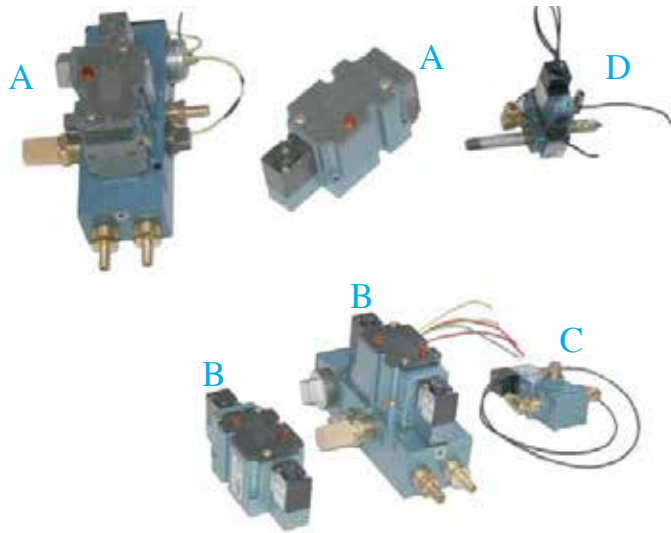

Hand Valves

Description	Part #
Norgren Super Spool Valve	K81EA00KCOKL2
Norgren Vibrator Black Spring	K41EA00KS1KBO
Norgren Aeration Red Locking	K41DA00KCOKB4



Description	Part #
Schrader Bellows Stand Alone Single	VAL 7053910253
Schrader Bellows Stand Alone Double	VAL 6953921153
Schrader Bellows Manifold Single	VAL 6753910253
Schrader Bellows Manifold Double	VAL 6653921153

Description
Schrader Bellows Valve Stand Alone Complete Single

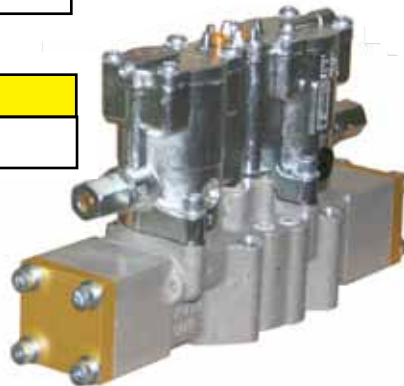

Description
Schrader Bellows Valve Manifold Complete Double

Note: Other sizes and Parts numbers are also available

Repair Kit for Solenoids

Description	Part #
Aeration Solenoid Repair Kit Mac	K55001
Single Solenoid Repair Kit Mac Old Style	K63008
Double Solenoid Repair Kit Mac Old Style	K63011
Single Solenoid Repair Kit Mac New Style	K63016
Double Solenoid Repair Kit Mac New Style	K63019
Water Solenoid Repair Kit Mac	K-09006
Kit for PRK Valve K175903553	K-352166
Schrader Bellows Valve Solenoid Single Repair Kits	K352-124
Schrader Bellows Valve Solenoid Double Repair Kits	K352-126

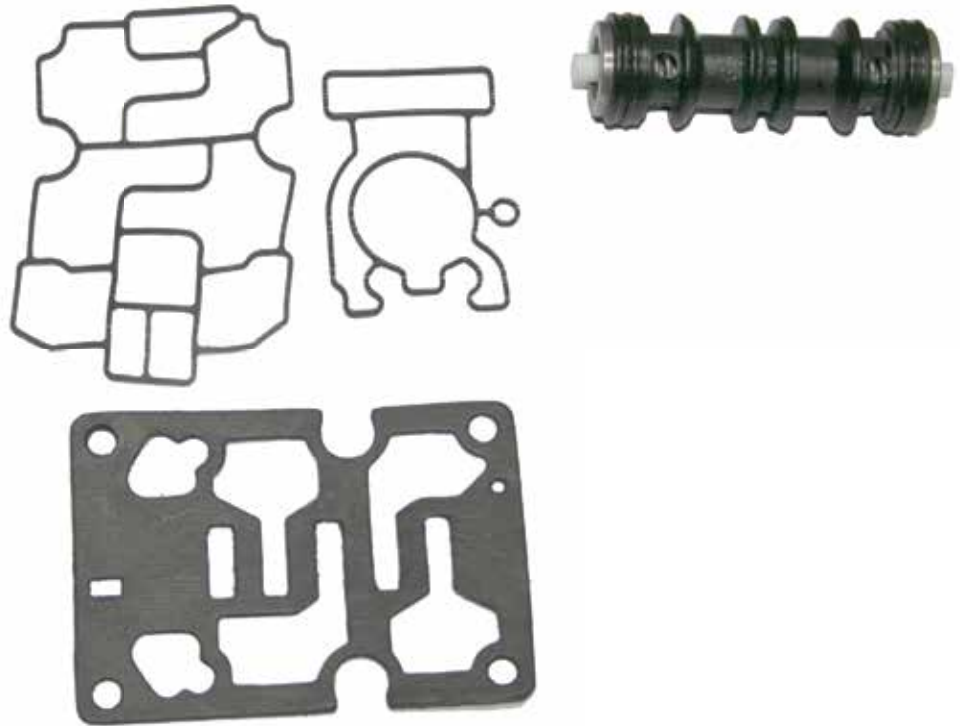

AAA Solenoid Valves

Description	Part #
AAA Double Solenoid	S040L
AAA Single Solenoid	S030L
AAA Double 3/8" Solenoid	SY40L
AAA Single 3/8" Solenoid	SY30L



Drive Sprockets

Description	Part #
Sprocket for Jackshaft Transfer Conveyor (Motor)	H60P13
Sprocket for TurnHead (Motor)	H60P14
Sprocket for Power Travel (Red)	H80Q19
Sprocket for TurnHead (Shaft)	60Q60
Sprocket for Jackshaft Transfer (Shaft)	60Q72
Sprocket for Radial Stacker (Hub)	80A50



Chains

Description	Part #
60 Rivet Chain (For TurnHead)	J60
80 Rivet Chain (For Power Travel)	J80
Master Links 60	ML60
Master Links J80 #332282	J80C/P

Silo & Batcher (Transition Kits)

Description	Part #
Slide Gate 10"	E.S.-10
10" Butterfly Valve	Grinnell or Bray
10" Collar & Flange	C-10
Air Cylinder Bracket	ACB 10" Grinnell or Bray
3-1/4" X 8" Cylinder	ST3P2325X8SP530



8"-10"-12"

Transition Emergency Slide

Slide Plate



8"-10"-12" Transition

12" Collar & Flange

8"-10"-12" Flat Flange



20X20

8"-10"-12" Collars
on 16" Square Plate

Boot 12" long X12"

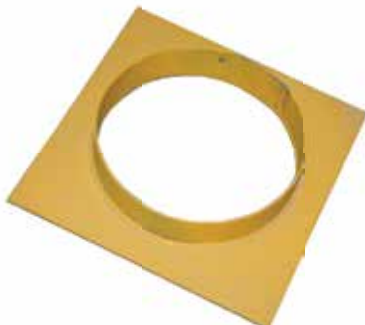

12" Ring

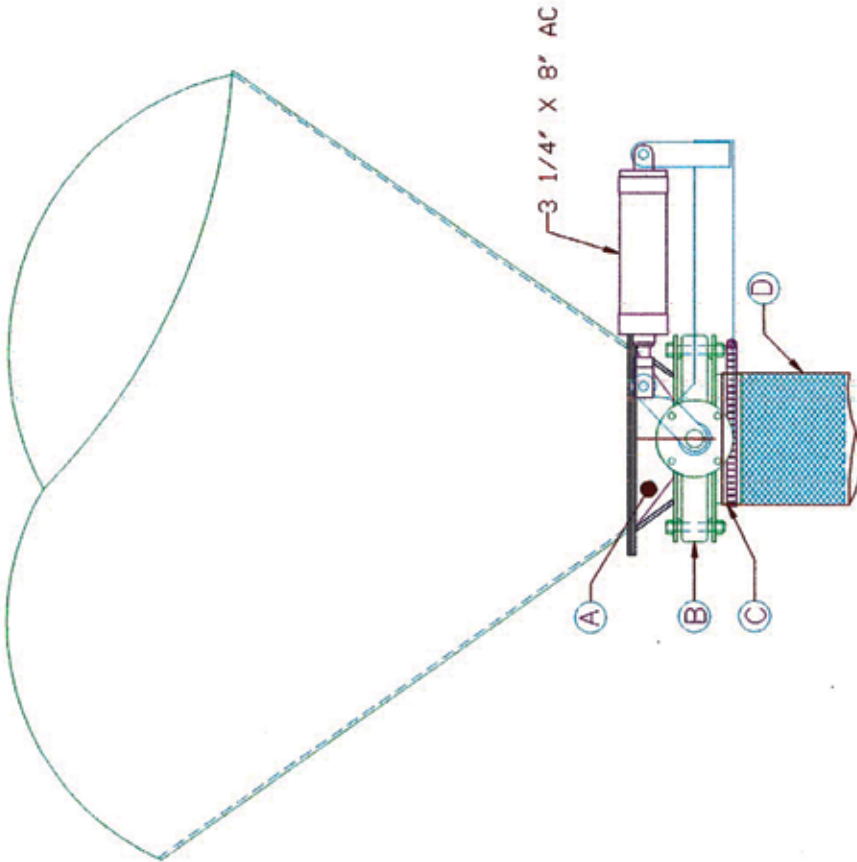

MARK	DESCRIPTION
(A)	TRANSITION FROM EXISTING SILO FLANGE
(B)	10" DIA. BUTTERFLY VALVE WITH AIR CYLINDER
(C)	10" COLLAR (FLUME HOOKS TO IT WITH CLAMP)
(D)	10" DIA. FLUME

Cement Batcher Transition

Silo Transition Assembly

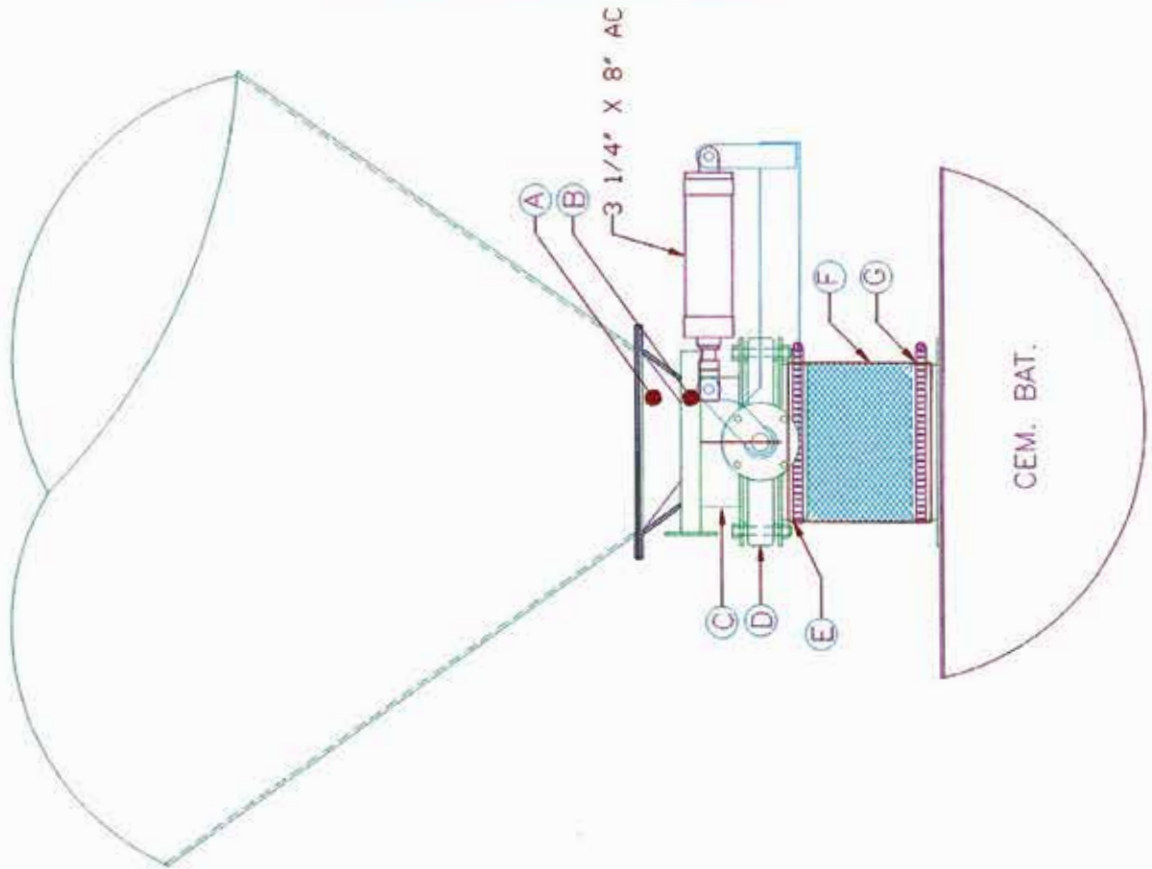

MARK	DESCRIPTION
(A)	TRANSITION FROM EXISTING SILO FLANGE
(B)	EMERGENCY SLIDE PLATE
(C)	10" COLLAR
(D)	10" DIA. BUTTERFLY VALVE WITH AIR CYLINDER
(E)	12" COLLAR (FLUME HOOKS TO IT WITH CLAMP)
(F)	12" DIA. FLUME
(G)	12" COLLAR ON 16" SQUARE PLATE TO WELD ON EXISTING CEMENT WEIGH HOPPER FLUME CONNECTS WITH HOSE TYPE CLAMP



Description	Part #
Old Style Collection Hopper	151-153 24"
Old Style Collection Hopper	159- A-D 30"
Old Style Collection Hopper	147-150 36"
Titan Colection Hopper	228-232 30"
Titan Colection Hopper	317 NC 36"
Bolt-in Side Liners	30" Liner

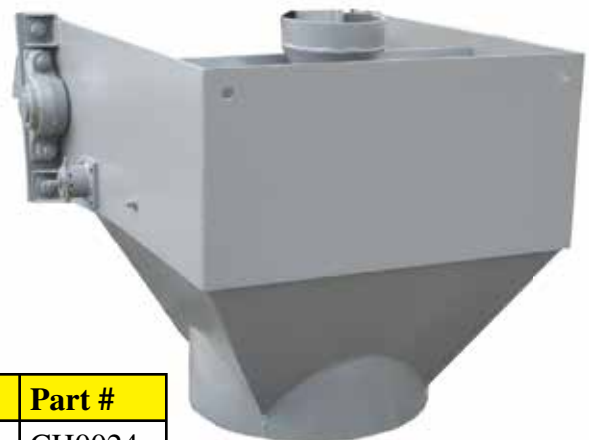

Description	Part #
24" Collection Hopper	CH0024
30" Collection Hopper	CH0030
36" Collection Hopper	CH0036

Collection Hopper/Truck Collection Hopper Components

Vibco Silent Turbine (Cement)

Turbine Type Air Vibrators

Description	Part #
Rotary Air Vibrator Small	VS-190
Rotary Air Vibrator Large	VS-380



BEST BY TEST

DBA — NOISE — LIFE CURVE

Turbine vibrators maintain 70-75 db's throughout their entire life, as compared to sharp increases in noise levels of ball roller and piston type vibrators. Turbine sound levels actually reduce after a short "break-in" period and retain a constant low sound level throughout their life. Although ball and roller vibrators start at under OSHA limits, they very quickly and steadily increase noise levels to well above OSHA, to beyond bearable range. (See curve.) This is caused by ball or roller jumping and accelerating each time it passes the air inlet, causing pitting and continuing wear to the ball and races.

A turbine vibrator outlasts a ball vibrator 3 to 1.

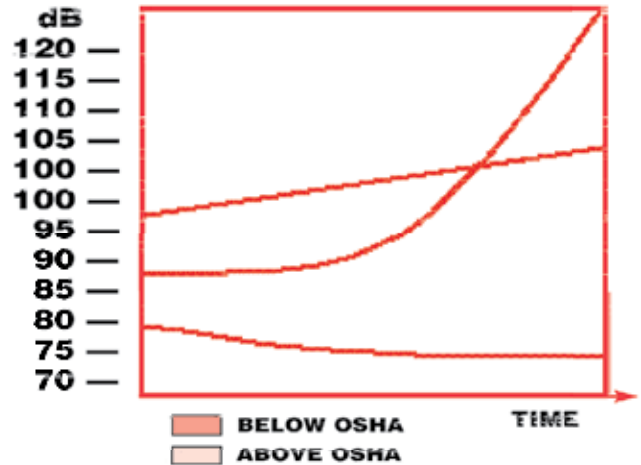

Description	Part #
Cleveland 1-1/4" Piston	1125VMS
Cleveland 1-1/2" Piston	1150VMS
Cleveland 2" Piston	1200VMS
Piston Vibrator AGG	55-2
Piston Vibrator AGG	55-3

Piston Air Vibrator



Vibco Electric Vibrators

Description	Part #
Electric Vibrator 3-Phase	2P 450-3
Electric Vibrator 110/220 Volt 1.PH (Aggregate)	2P450-1

Note: Other sizes available to work on most all applications

Part #	Description
P/N 3284	Weld on Handle for Vent door



Part #	Description
P/N 510	3/8"- 16 Handle Zinc PLT



Part #	Description
P/N Eye Bolt 12358	3/8" X 2 1/2" Rod end Eye Bolt



Tank Flanges

Description	Part #
1/8" Tank Flange / Weld-0-let	TKFL18
3/8" Tank Flange / Weld-0-let	TKFL38
1/2" Tank Flange / Weld-0-let	TKFL12
3/4" Tank Flange / Weld-0-let	TKFL34
1" Tank Flange / Weld-0-let	TKFL1
1 1/2" Tank Flange / Weld-0-let	TKFL112
2" Tank Flange / Weld-0-let	TKFL2
3" Tank Flange / Weld-0-let	TKFL3



Water Meter

Description	Part #
2" Badger Water Meter Complete	BAD 258094-2"
3" Badger Water Meter Complete	BAD 258095
4" Badger Water Meter (PFT4E) 1000 Gal/Min	258141
2" Y Strainer	MULL 2
3" Y Strainer	MULL 3
4" Y Strainer	MULL 4
Threaded Hose Barb 2" & 3"	DISTC25/DISTC35
Act Counter for Water Meter	356B350Q30PX
2" Bray Actuator	BF-2A
3" Bray Actuator	BF-3A
4" Bray Actuator	BF-4A
Bray Limit Switch	501600-24603536
2" Bray Butterfly Valve	BF-2
3" Bray Butterfly Valve	BF-3
4" Bray Butterfly Valve	BF-4
Water Meter Solenoid	912BPM112CA
1/4" Restrictor Muffler	C28
2" Water Stand	PT2233
3" & 4" Water Meter Stand	PT2234
2" Badger Magnetaflow	67772-003A
3" Badger Magnetaflow	67772-004A
4" Badger Magnetaflow	67772-005A
O-Ring	BAD 258042
Tetraseal	BAD 258050
Head Gasket	BAD 258052
PFT4E Transmitter	BAD258093

Parts for Water Meter

Description	Part #
Scaler Board only	250256
Rotor & Spindle 2" 2 Pole	258072
Rotor & Spindle 2" 4 Pole	258047
Rotor & Spindle 3" 2 Pole	258073
Rotor & Spindle 3" 4 Pole	258048

Note: All Water Meter Parts available

Water Meter Complete



Mag Water Meter

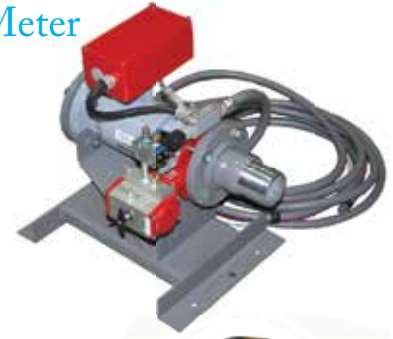

Bray Limit Switch



Meter Only



Water Meter Control Box



Water Meter Solenoid



Restrictor Muffler



Y-Strainer



B-Valve, Actuator & Solenoid



Hose Barb & Flange



Top View Water Meter Stand

Water Pumps

Plant Batch Water Pumps	
3" x 3" 10HP 250 GPM	4261-95
2" x 1/2" 2HP 175 GPM	3157-95



Pump Accessories	
2" x 50' Discharge Hose	HPWO2050
1-1/2" x 50' Discharge Hose	HPWO1550
2" x 20' Suction Hose	HPWS2050
1-1/2" x 20' Suction Hose	HPW1550
2" Strainer	ST-200-TP
1-1/2" Strainer	ST-150-TP



Gorman Rupp & AMT Water Pumps	
2" Gas Pump with Honda	12D1-GX160
Electric 1-1/2"	3166-95
2" AMT Submersible	2X11



Aeration Blower ROOTS

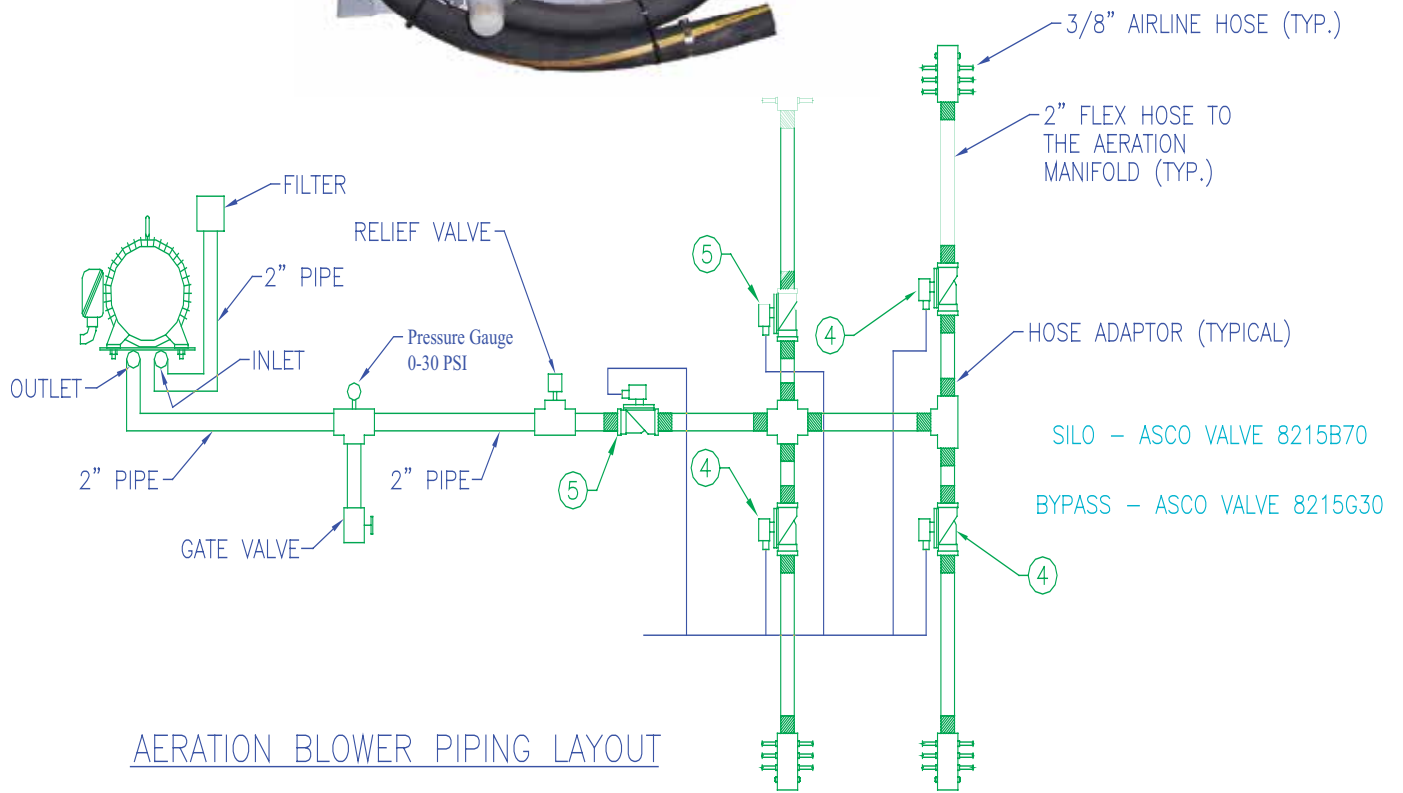

AERATION BLOWER PIPING LAYOUT

Description	Part #
Boots Blower MDL	33URA1
Inlet Filter	EMF-25-060124
Pressure Relief Valve	13-214-06
0-30 PSI	T8B-L
Gate Valve	206.1
Asco Valve 120/60-1 1/2	8215B70
Asco Valve 120/60 1/4	8210G54
Aeration Manifold	AM895623S0

Aeration Blower FUGI

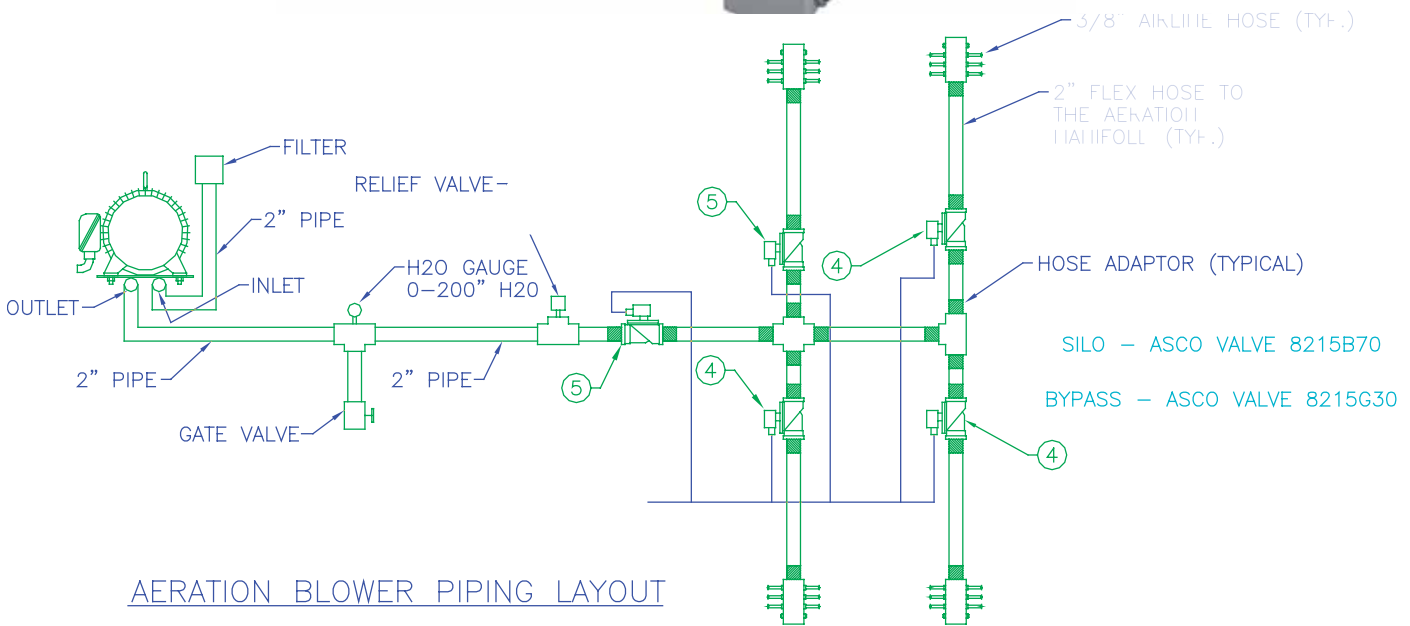

AERATION BLOWER PIPING LAYOUT

Description	Part #
4.5 HP Blower	604A-7W
Fleet Guard Av Cleaner	AH1140
Pressure Relief Valve	PV-6
Static Pressure Gauge 25.200.200	25.200.200
1" Gate Valve	206.1
Asco Valve 120/60-11/2 {Air}	8215B70
Asco Valve 120/60-1/4	8210G54
Aeration Manifold	AM895623S0

TurnHeads 6Ft.6" Hight. and 7Ft. Hight

Description	Part #
Flange Bearing (TurnHeads)	F3U232N
TurnHead Shaft with 1/2" Key Way	2" X 42-1/2"
Reducer (Dodge) TurnHead	(M94408)
Motor (1/2HP)	VL-3504
Bushing (Red)	P1- 7/8
Sprocket (Red)	H60P14
Sprocket (for) Shaft	60Q60
Bush (for) Shaft	Q1-2
Limits Switch	9007-C54B2
Limit Switch Arm 1 1/2"	9007-MA18
Chain	J60



Chute Parts

Description	Part #
Bearing Two Bolt Flange Brg.2"	FX3Y2E32N
Shaft	2" Shaft 37" or 43"
Cylinder 3/4" X8" Star	ST3P2325X85P530
Solenoid 6300 Mac Single	6313D611PM112DA

2 Way



3 Way



Filter Vent Magnehelic Gauge Kit

Part #	Description
P/N - 44P	1/4" Poly - tubing

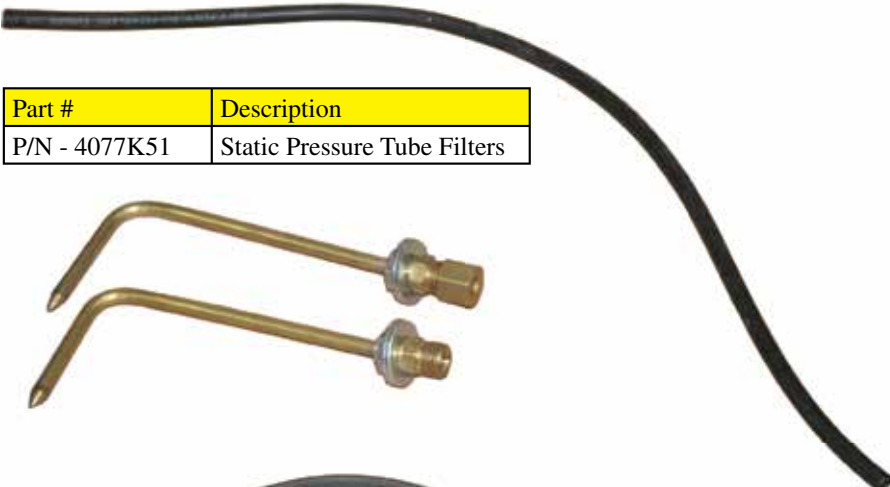

Part #	Description
P/N - 4077K51	Static Pressure Tube Filters



Description
1/8" NPT - Tap



Description
Q Drill Bit



Part #	Description
P/N 18-179L	1/4" Comp X 1/8 MPT STR



Part #	Description
P/N 2010	0-10" Static Pressure Mag Gauge
MA 014	Mini-Helic Gauge
MA 015	Mini-Helic Gauge & Hose Kit
HC012	3/16" Clear Vinyl Hose



Part #	Description
P/N 22-010	1/4" Brass Insert



Magnehelic Gauge Kit



SV-20 Batcher Vent mounts on top of the cement Batcher. The filtration process occurs when displaced air is forced through bags and clean air is pulled through the bags when the batcher discharges. (Dimensions are: 22-3/4" H, 37" L, 9-1/2" W. The unit weighs approximately 115 Lbs.

Side View



Gate View

SOS-80 (Cartridge Type)

The SV-45 and SV-65 Filter Vents mount on the side of the silo with flexible 6" diameter hose connecting the vent to the Cement Batcher. The bags are cleaned by a 1/3 HP single phase motor that is activated when the batcher gate opens.

Vent	Height	Width	Length
SV-45	79"	21"	39"
SV-65	79"	30"	39"



C&W

Part #	Description
CP-35	Pulse Jet



- **Stephens Filter Vents** provide highly effective dust control for cement, flyash, and other granular material.
- **Dual-Density Filter Bags** of Polyester/Dacron fibers trap 99.6% of moving dust particles, allowing the release of clean air into the atmosphere. Valuable materials are then recycled for reuse.
- Vent Housing is of a high quality steel and the full length access door allows for easy maintenance and service of bags.
- **Blowers** are available for all units. Call 1-800-626-0200 for complete information.



Filter Bag Specifications:

Fiber.....Polyester / Dacron
 Construction.....Felt, Duo-Density
 Air Permeability.....30-40 CFM Sq.Ft.
 Temp. Range.....220°-440°F
 * Recovery.....99.6% to one Micron size

Model No.	No. Of Bags	Bag Sizes	Cloth Area	Approx. Wit.	Dim 'A'
SV-170	16	7" Dia x 72"	170 Sq. Ft.	750 Lbs	36"
SV-265	25	7" Dia x 72"	265 Sq. Ft.	875 Lbs	44"
SV-380	36	7" Dia x 72"	380 Sq. Ft.	1,000 Lbs	54"

Stephens Filter Vents can meet all local, state and federal air pollution regulations.

Note: We reserve the right to amend standard specifications without notice.

Features:

- Easy to replace cartridges, no tools required and no confined space. Cartridges replace from outside vent.
- Cartridges cleaned semi automatically by pulse reverse air for continuous cleaning.
- All Parts and cartridges are kept in stock.

Cartridge Specifications:

Fiber.....100% Polyester
 Construction.....Non-Woven, Pleated
 Temp. Range.....200 Degrees
 Recovery.....99.95% to 1 micron and above

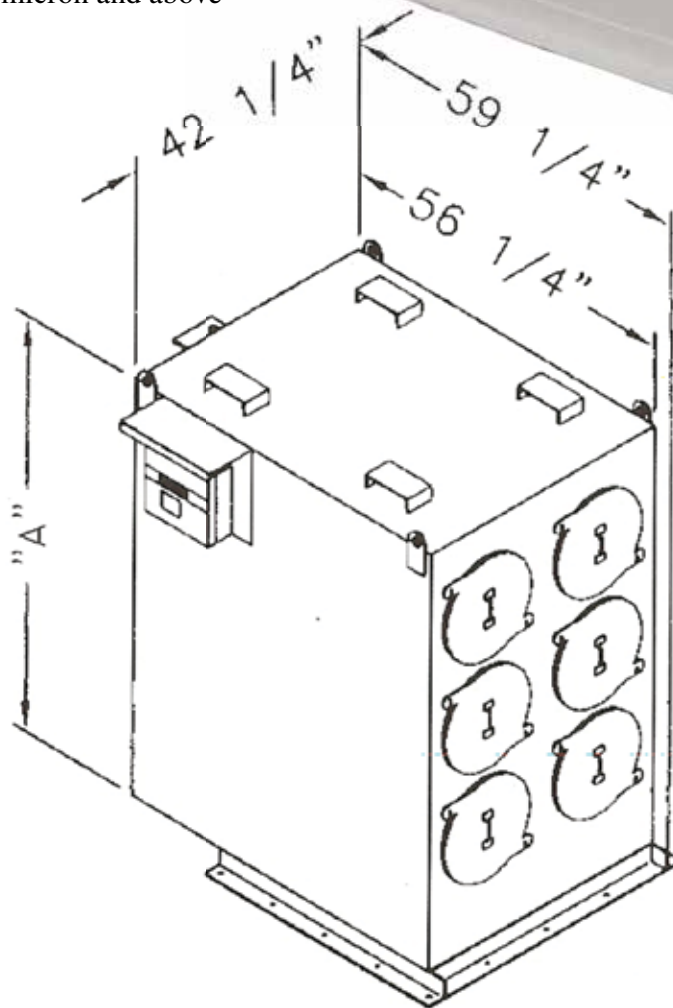

Model No.	No. of Cartridges	Cloth Area	Dim 'A'
SOS-1020	3	450 Sq. Ft	4'4"
SOS-1360	4	600 Sq. Ft	4'4"
SOS-2040	6	900 Sq. Ft	5'0"
SOS-1020X2	6	900 Sq. Ft	5' 0"

Ross Silo Dust Collector	
3CP-250 Cartridge Filter	10001411
V-200 Bag Filter	FI 81-4X84

Wam Parts	
Safety Pop-Off	VCP2731/V
Wam Dust Filters	C003PPY
Wam Oval Filter Cartridge	KFEW30/07PPVE
Proximity Switch	ELE55BLT1C
2" x 8" Schroeder Bellows Cylinder	CY2X8CY

Belgrade Silo	
Belle Style 16 sq. ft. Batcher Vent	10001411
Belle Style Batcher Vent Filter Bag	8X24
Belle Style 150 sq. ft. Filter Bag	8X4
Belle Style 225 sq. ft. Filter Bag	8X6
Vibrator Shaker Motor	VS-190



Johnson-Ross 3CP-250

Shaker Mechanism - Replacement Parts

Shaker Drive Train Kit

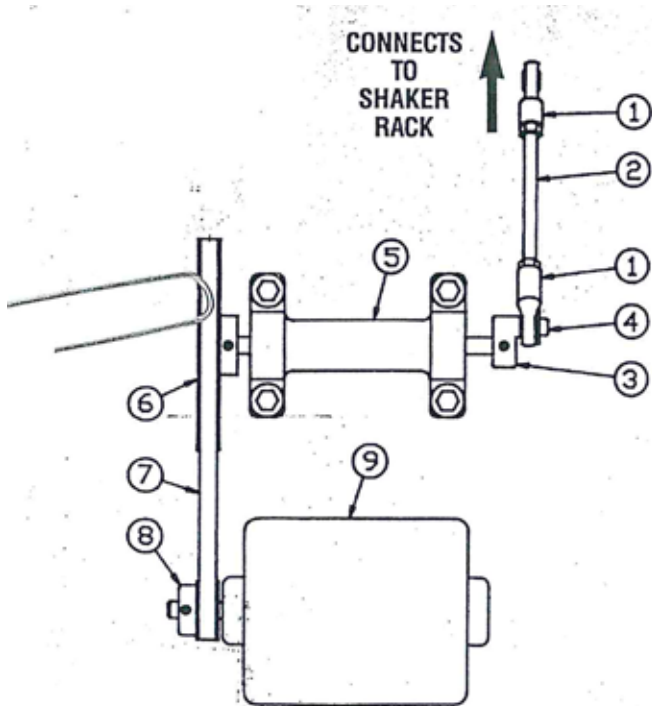

Part #	Description	Qty
825-RK1	Fits most filter vents with 36 bags and others. Includes all set screws, washers, and other hardware for Parts 1-5	
1. 400-PF-6	3/8" Radial Bearing	2 pcs
2. 250-387MSF	3/8" x 7" Mill Stud-fine	1
3. 400-ECC12B	1/2" Brass Eccentric	1
4. 250-FS1658SB	5/16" x 5/8" Shoulder Bolt	1
5. 400-6-8X956	1/2" Saw Mandrel	1

Additional Parts (available separately)

6. 400-AK641/2	Large Pulley 6" PD x 1/2" Bore
7. 400-4L290	V Belt
8. 400-AK171/2	Motor Pulley
9. Motor	Several models available. Please call.

Bag Parts (additional hardware)

740-6FBD	6" Fiber Disk - disk top bags
740-4FBD	4" Fiber Disk - disk top bags
250-F14SH	J Hook - To hang grommet top bags
250-6464HCS	Hose Clamp - 4" D Cuff Bottom Bags



Gauges

#2020 Magnehelic Gauge	MA013
“Mini” Helic magnehelic Gauge	MA014
“Mini” Helig Gauge Field Retro-Kit	MA015
3/16” Clear Vinyl Hose for Magnehelic Gauge	H0012

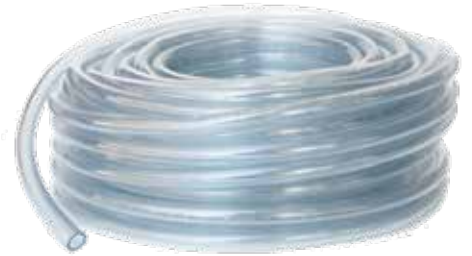

Chains

5/16” x 1-1/2” System 3 Proof Coil Chain	CH000
Lap Link 5/16” x 1-1/2” Chain	CH001
“D” Link - 5/16” Quick Link Chain	CH004

Shroud Bearings

2 Bearing, Pillow Block 1”	BR008
2 Bearing, Pillow Block 1-1/4”	BR013

Pulleys

Sheave, Standard 5/16”	CB007
Sheve, Heavy Duty	CB001
Sheave, Steel w/Brushing	CB004

Curtains

Rubber Belting 60” PVC 90 for Shrouds	RB005
---------------------------------------	-------

Return Blowers and Parts

2" Return Blower Filter F8-108 (6-3/4" x 4")	RT021
3" Return Blower Filter F8-109 (10" x 5-1/4")	RT013
2" Return Blower Filter w/Housing	RT019
Recycle Return Blower (Gardner Denver/Sutorbilt)	RT020
1 Return Blower Filter Element & 1 Quart Oil	RT020 Kit

Return Hoses

2" Cement Hose "Bull Hose"	H0007
3" Cement Hose "Bull Hose"	H0010
4" Cement Hose "Bull Hose"	H0011
5" Cement Hose "Bull Hose"	H0009
2" - 5" Hose Clamp	HC001

Return Pipe

2" Half Nipple	PF093
3" Half Nipple	PF041
3" 180 degree Elbow	CW176
2" 180 degree Elbow	CW269
2" Steel Pipe	ST200
3" Steel Pipe	ST072

Door Parts

"Hook" Style Door Handle, CP-Series	D0002
Rubber Door Trim (available in foot long sections)	RB007
Rubber Door Seal for Hopper - Flat	RB001
MCP Door Latch/Handle (used on Modular Units)	D0007
MCP Door Limit Switch (used on Modular Units)	EB199

Camlock Fittings

	2"	3"	4"	5"
OC Camlock	CM015	CM001	CM006	CM010
Dust Cap	CM019	CM011	CM004	CM023
OF Camlock	CM014	CM003	CM007	CM024
KC Camlock	CM018	CM008	N/A	N/A
OA Camlock	CM016	CM000	CM005	CM017
OD Camlock	CM013	CM002	CM012	N/A

Ducting

3" Aluma Grip Duct Tape	T0002
6" Vent-a-Hood	VE000
12" Aluminum Slide Gate	BS004
14" Aluminum Slide Gate	BS005



Electrical Timers

360-120-1 Second 8 Pin	ET000
360-120-1 Minute 8 Pin	ET001
361-120-1 Second	ET002
TM 261A-120 2 Stage Alternator 8 Pin	ET003
120 Volt Relay 8501 KPIZV	ET004
368-120-1 Second (Double Timer) 8 Pin	ET006
Goyen 4 Pole Time Board 12 V	ET010
361-120-1 Minute Timer	ET011
4-12 Pole Digital Timer Board - Goyen (for central)	ET077
E/T Socket & Pin	ET012



ITEM	QTY.	DESCRIPTION	P/N
1	12	ø8" X 78" HEAVY-DUTY CARTRIDGE	CD011
2	1	ELECTRICAL CONTROL PANEL	X
3	1	FILTER/REGULATOR W/ WATER SEPERATOR	FT004
4	1	MINI-HELIC GAUGE	MA014
5	1	AIR VIBRATOR	VI005
6	1	6" BUTTERFLY VALVE	BF004
7	3	1 1/2" SOLENOID VALVE	SD010
8	3	1 1/2" DOUBLE BULKHEAD CONNECTOR	SD025
9	1	HDBI-160-85% BLOWER	BL069
10	1	6" BUTTERFLY ACTUATOR	BF007

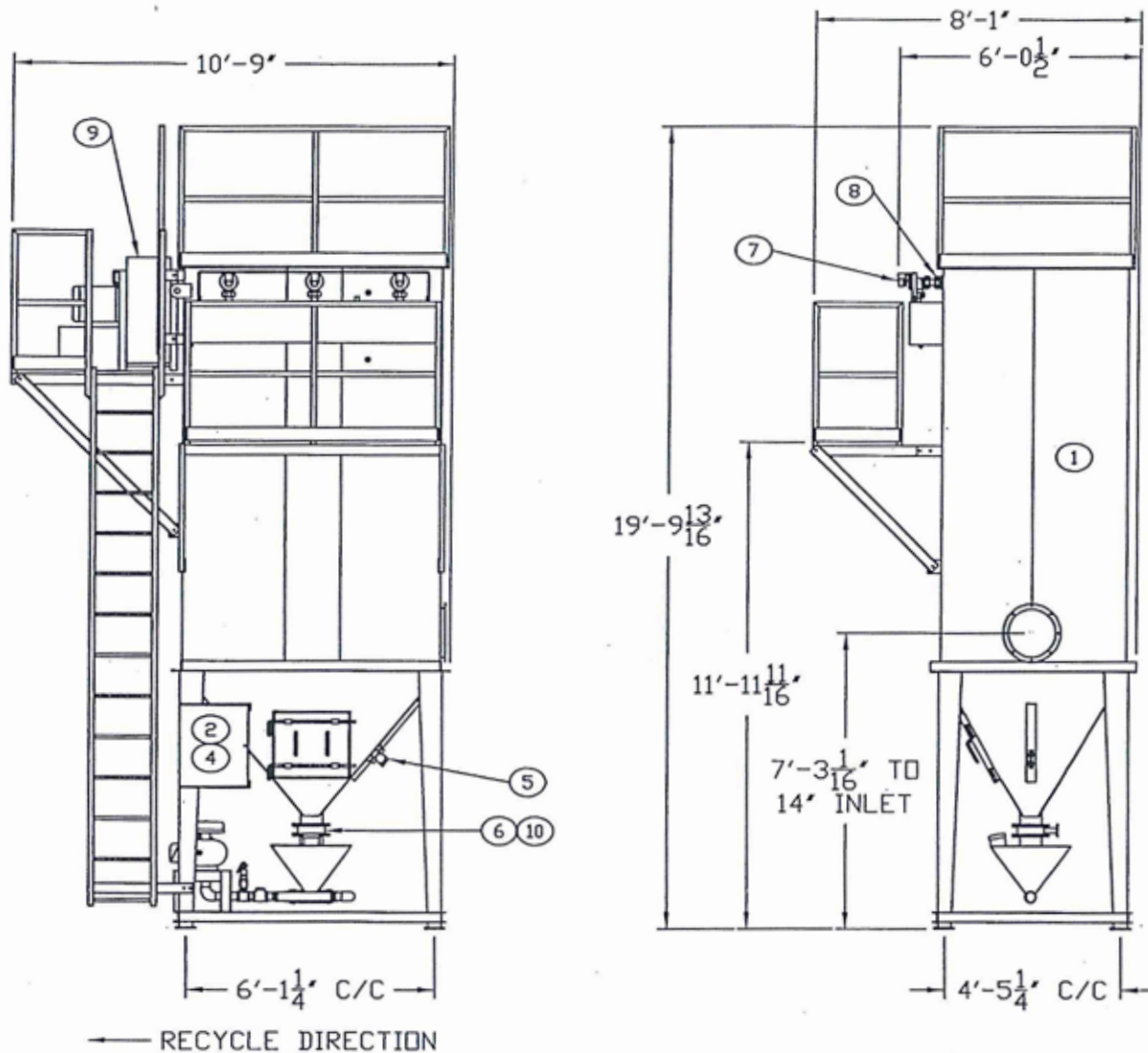

CP-900/ 5250
 CARTRIDGE PULSE COLLECTOR
 WITH OPTIONAL RECYCLE

****Parts for CP-7500, CP-10000 available****

PARTS LIST FOR RA-140

ITEM	QTY.	DESCRIPTION	MFG.
1	1	MOTOR, 10 H.P./ 1750 RPM	MT010
2	1	BLOWER, NORTHERN 2000	BL050
3	3	BELT, 3VX-850	BE024
4	1	MOTOR SHEAVE, 3GR-3V 6.9 (SDS)	SH037
5	1	BLOWER SHEAVE, 3GR- 3V 5.6 (SDS)	SH031
6	1	MOTOR HUB, 1 3/8" SDS	HB000
7	1	BLOWER HUB, 1 11/16" SDS	HB004
8	2	AIR CYLINDER, 2 1/2" X 6"	ACA001
9	3	1/4" SOLENOID	SO017
10	72	BAG, 8"Ø X 114" LG.	BO001
11	1	MINIHELIC GAUGE	MA014
12	1	8" BUTTERFLY VALVE	BF001
13	1	8" BUTTERFLY VALVE ACTUATOR	BF003
14	1	8" BUTTERFLY VALVE/ACTUATOR ADAPTER	BF002
15	1	VIBRATOR	VI005
16	1	AIR FILTER/ REGULATOR	AL004

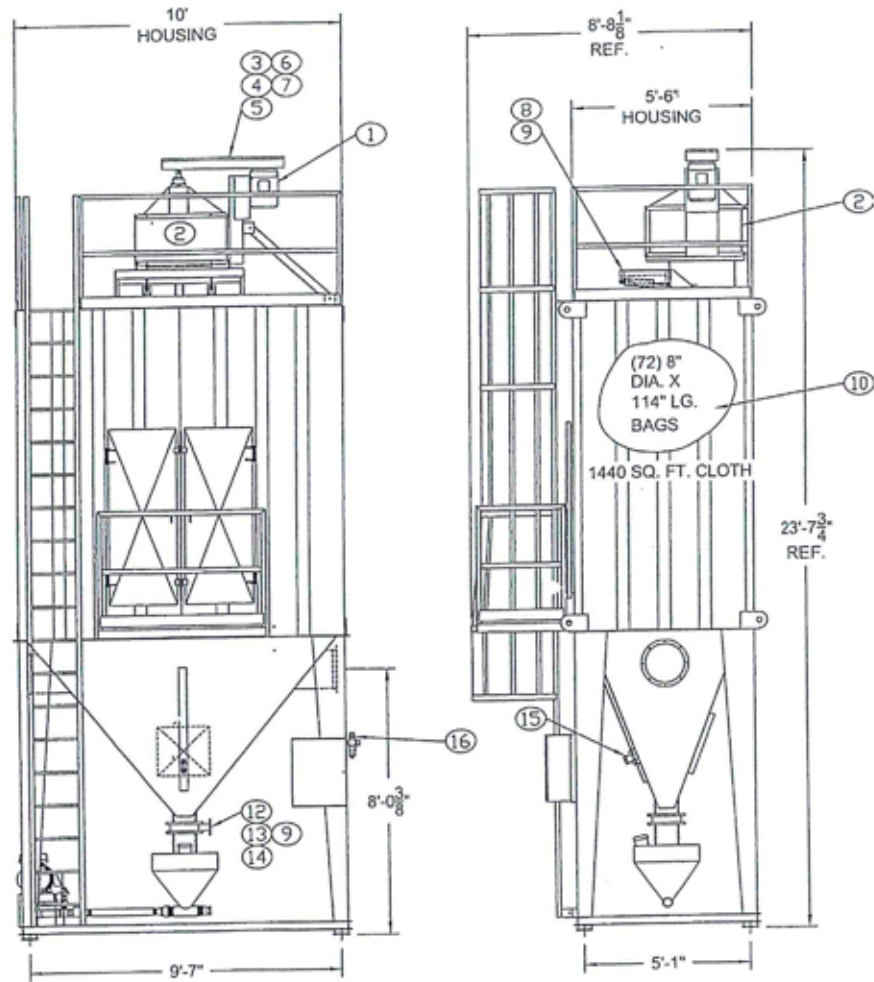

RA-140 DUST COLLECTOR
PARTS LIST

ITEM	QTY.	DESCRIPTION	C&W P/N
1	1	AIR INTAKE FILTER	RT019
2	2	2" NIPPLE X 5" LG.	PF034
3	2	2" THREADED 90° ELL	PF036
4	1	2" NIPPLE X 8" LG.	PF016
5	1	2" X 2" X 1" PIPE TEE	PF057
6	1	RELIEF VALVE	RV002
7	1	1" STREET ELL	PF085
8	1	2" CLOSE NIPPLE	PF060
9	1	2" CHECK VALVE	CK001
10	2	2" K.C. NIPPLE	CM018
11	2	2" WORM GEAR HOSE CLAMP	HC001
12	1	2" CEMENT BULL HOSE X 24" LG.	H0007
13	2	3" X 2" BELL REDUCER	PF058
14	1	CAMLOCK, 2" A-STYLE	CM014
15	1	MOTOR, 7.5 HP 3450 RPM	MT008
16	1	POSITIVE DISPLACEMENT BLOWER	RT020

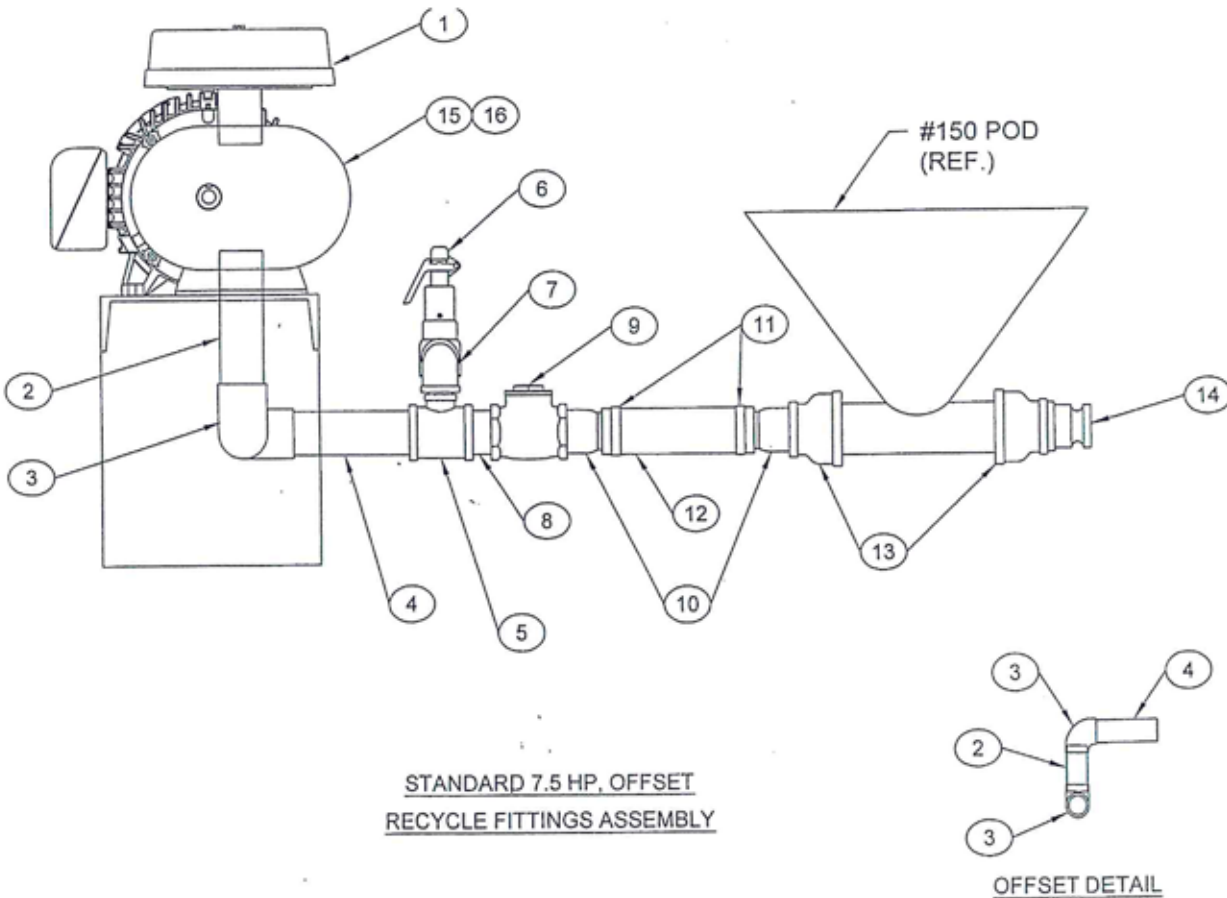

****Parts for RA-120, RA-170, RA-200 available****

C & W LPR - 6/8

ACAD/DRAW/NEVEST/GA/CP-LPR-S

NOTE: THIS PRINT NOT FOR CONSTRUCTION. FOR GENERAL REF. ONLY

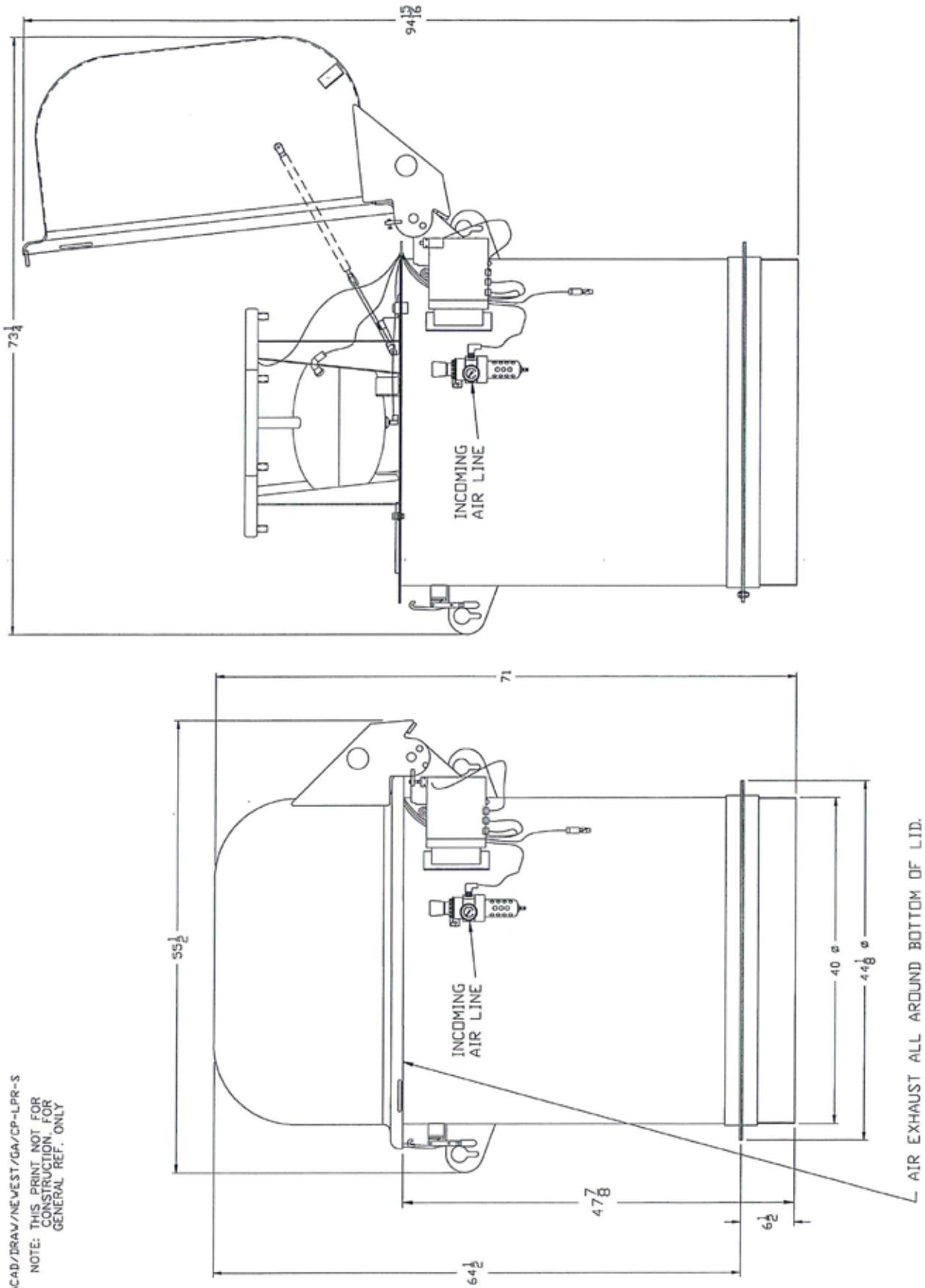

CARTRIDGE PULSE SILD COLLECTOR, LOW PROFILE ROUND
TYPICAL FOR CP-LPR-8-S, CP-LPR-6-S, CP-LPR-4-S



Low Profile Round Silo Dust Collectors

General Information

C&W's Low Profile Round (LPR) Silo Dust Collectors offer you Pulse-Jet technology and our cartridge filters to provide an efficient yet inexpensive solution for dust control. These collectors are compact and user-friendly with a low-profile and POP in-out filter media exchange, with no tools or need to remove blow pipes. They can also expand to higher capacities without having to replace the units.

Options

- Automatic On/Off Flow Switch
- Minihelic Gauge
- Special Adaptable Mounting Flange
- Air Tank Auto-Drain
- Silo Anti-Overfill System
- Pressure Relief Valves and Bin Indicators

Specs

Specifications	LPR-4-S	LPR-6-S	LPR-8-S
Total Filtration Area (sq. ft.)	184	276	368
Number of Cartridges	4	6	8
Cartridge Size	8" x 39"	8" x 39"	8" x 39"
Air to Cloth Ratio	6.35	6.37	6.35
Overall Height *	72"	72"	72"
Flange Diameter	44" o.d.	44" o.d.	44" o.d.
Approx. Weight (lbs.)	670	695	720
Compressed Air Required	3	3	3
CFM Recommended**	1,170	1,760	2,340
Min. Design Efficiency***	99.99%	99.99%	99.99%
Cleaning Mechanism	Pulse Jet	Pulse Jet	Pulse Jet

*Includes Mounting Flange change CFM recommended ** CFM shown for typical application. Unique application may
 ***Using Standard Test Conditions



Protect your silos and silo collectors with an Anti-Overfill System



Easy Cartridge Replacement: Pop-in/Pop-Out



C & W Silo Collector Parts

CP Silo Collector Spare Parts		
CP-35		
Qty	Part #	Description
2	SO008	3/4" Solenoid Valve - threaded
1	ET025	4 Pole Digital Timer Board - Goyen
2	CD028	8" x 19" Polyester Cartridges
CP-70 & CP-88		
Qty	Part #	Description
2	SO008	3/4" Solenoid Valve - threaded
1	ET025	4 Pole Digital Timer Board - Goyen
4	CD028	8" x 19" Polyester Cartridge
CP-1335S - CP-5000S (Formerly CP-230,300,305,450)		
Qty	Part #	Description
	SO02C	3/4" Solenoid Valve - threaded
2	SO002	1" Solenoid Valve - threaded
1	ET025	4 Pole Digital Timer Board - Goyen
4+	CD029	8" x 39" Polyester Cartridge
CP-LPR Series		
Qty	Part #	Description
2	SO048	1" threaded solenoid valve (July 7 - current)
1	ET077	4 Pole Digital Timer Board - Goyen
4+	CD029	8" x 39" Polyester Cartridge

Gauges, Shrouds, & Lifframes

Part #	Gauges
MA013	#2020 Magnehelic Gauge
MA014	"Mini" Helic Magnahelic Gauge
MA015	"Mini" Helic Gauge Field Retro-Kit
H0012	3/16" Clear Vinyl Hose for Magnehelic Gauge

Part #	Shroud Bearings
BR008	2 Bearing, Pillow Block 1"
BR013	2 Bearing, Pillow Block 1-1/4"

Part #	Chains
CH000	5/16" x 1-1/2" System 3 Proof Coil Chain
CH001	Lap Link 5/16" x 1-1/2" Chain
CH004	"D" Link - 5/16" Quick Link Chain

Part #	Pulleys
CB007	Sheave, Standard 5/16"
CB001	Sheave, Heavy Duty
CB004	Sheave, Steel w/Brushing

Part #	Curtains
RB005	Rubber Belting 60" PVC 90 for Shrouds

24" & 30" X 36' Long Transfer Conveyor

Mark	Description	24" Part #	30" Part #
1	Motor	P2153027 10HP	P2553029 15HP
2	Motor Sheave	455247	455247
3	Motor Bushing	120427	120427
4	Motor Bracket	(243392)	(24392)
5	Belts	5VX710	5VX800
6	Gear Reducer #244527	243501	244526
7	Gear Reducer Sheave	455249	455249
8	Gear Reducer Bushing	120425	120425
9	Turned 2 3/16" Shaft	MH27164836	MH27165436
10	Pillow Block Bearing	(126818) 2 7/16	(126818) 2 7/16
11	Head Pulley	12" X 26" Bushing SFQD 2 7/16	12" X 32" Bushing Type E
12	Wing Pulley	10" X 26" Bushing SFQD 2	10" X 32" Bushing SFQD 2 7/16
13	Pillow Block Bearing	(126815) 2"	(126815) 2"
14	Tube Takeup Units	2" PTB294240 12" Travel	2" PTB294240 12" Travel
15	Troughing Idlers	B4-35TE-24SB Precision	B4-35TE30SB Precision
16	Return Idlers	B4R-24-SB Precision	B4R-30-SB Precision
17	Titan Belt wiper	WB245TBW19	WB305TBW19

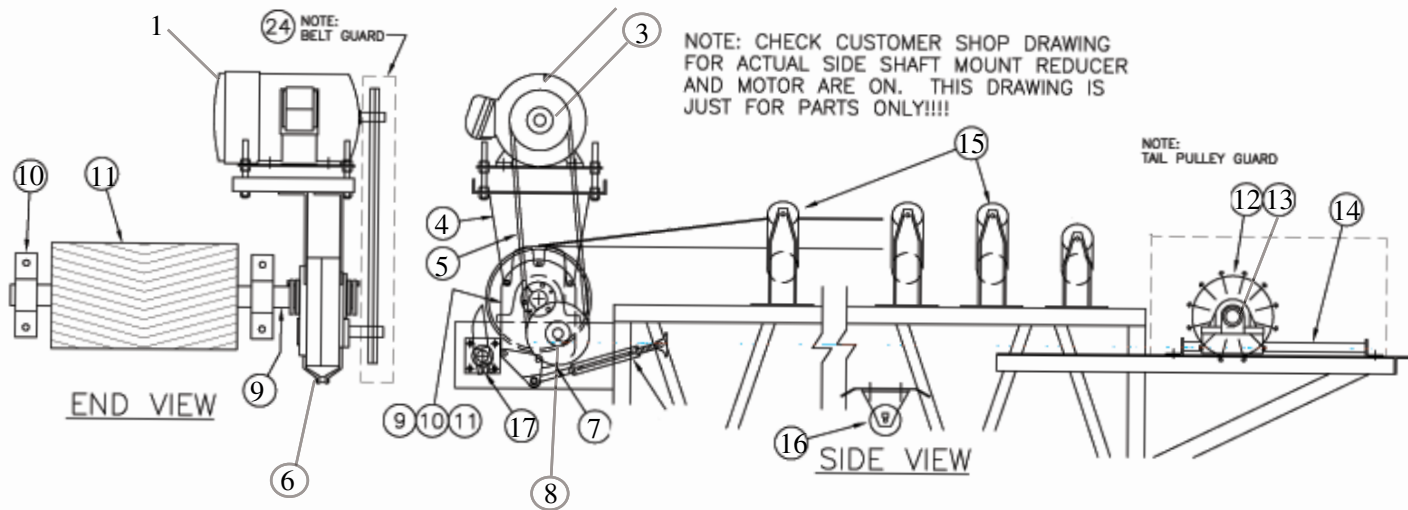

15 HP-24" Belt: Truss or Radial Stacker Conveyor Drive & Component Parts

ID	Item	Description	Qty.	Brand	Part#
1	Head Pulley	20" Dia. X 26" Face with 3/8" Lagging	1	Precision	H-XPD2026PXT35
2	Head Bearing	P2B-SCM-207 2 7/16	2	Dodge	126818
3	Head Shaft	2 7/16" X 48" Long (Check Length)	1	Stephens	MH27164824
4	Electric Motor	15 hp - 254T Frame - 1750 RPM	1	Reliance	P25S3029
5	Sheave (Motor)	2/5V7.1-SK (7.0" Pitch)	1	Dodge	455248
6	Bushing	SK-1 5/8	1	Dodge	120431
7	Motor Mount	TA4207MM (143-326T)	1	Dodge	904090
8	Drive Belts	5VX950 (Position B-M3~34.8 Centers)	2	Dodge	107195
9	Shaft Mount Reducer	TA4207H25 (207D25) 25.13-1	1	Dodge	904001
10	Red. Backstop	TA4207BS Backstop Assembly	1	Dodge	904102
11	Red. Taper Bushing	TA4207TB X 2 7/16	1	Dodge	904022
12	Red. Tie Rod	TA4207RA Rod Assembly	1	Dodge	904109
13	Sheave (Reducer)	2/5V9.25-SK (9.15" Pitch)	1	Dodge	455253
14	Bushing	SK-1 7/16	1	Dodge	120428
15	Tail Pulley	16" Dia. X 32" Face "Winged"	1	Precision	W-XPW1626PXT30
16	Take-up Unit	Typ. 24" Travel Truss Type	2	Stephens	12TU200M
17	Tail Bearing	P2B-SCM-207	2	Dodge	126818
18	Tail Shaft	2 7/16" Dia. X 35 1/4" Long (Check Length)	1	Stephens	MH2716352524
19	Belt Wiper	24" Titan Belt Wiper Assembly	1	Stephens	P24STBW19
20	Troughing Idler	24" Troughing Idler 20-Deg		Precision	B4-20TE-24SB
21	Troughing Idler	24" Troughing Idler 35-Deg		Precision	B4-35TE-24SB
22	Return Idler	24" Return Idler		Precision	B4-R-24SB
23	Conveyor Belting				
24	Drive Belt Guard	TA4207B/GB Belt Guard		Dodge	904096
25	Tail Pulley Guard	Fabricated in shop			

Notes & Revisions

Conveyor Information	
Shaft RPM	
Conveyor FPM	
Conveyor TPH	
Sheave Ratio	
Drive Belt HP	

24" Belt: Radial Stacker/Truss 60'-0" to 80'-0" with Screw Take-Ups

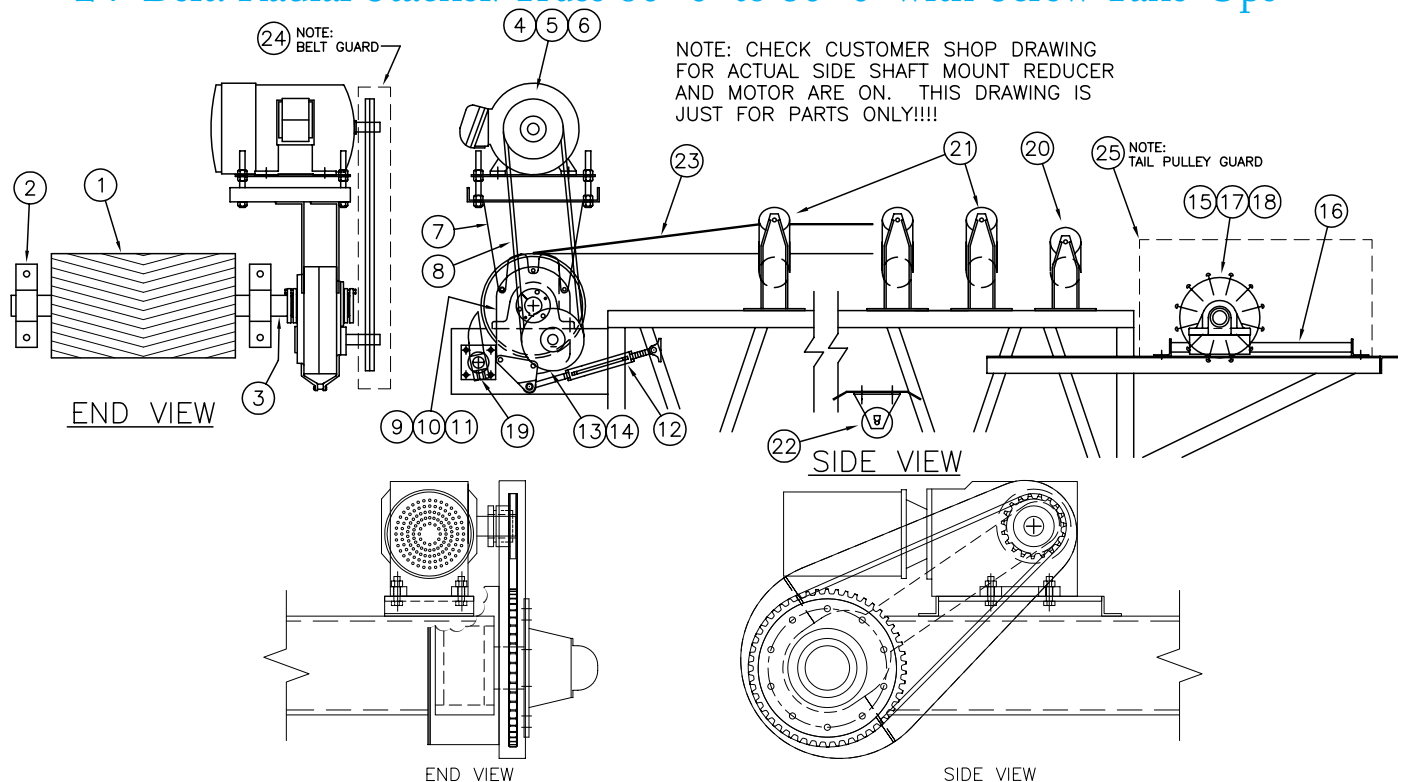

20 HP-30" Belt: Truss or Radial Stacker Conveyor Drive & Component Parts

ID	Item	Description	Qty.	Brand	Part#
1	Head Pulley	20" Dia. X 26" Face with 3/8" Lagging	1	Precision	H-XPD2032PXT30
2	Head Bearing	P2B-SCM-207 2/15/16	2	Dodge	126821
3	Head Shaft	2 15/16" > 2 7/16" at Reducer (check Length)	1	Stephens	
4	Electric Motor	20 hp - 254T Frame - 1750 RPM	1	Reliance	P25S3031
5	Sheave (Motor)	2/5V7.1-SK (7.0" Pitch)	1	Dodge	455248
6	Bushing	SK-1 5/8	1	Dodge	120431
7	Motor Mount	TA4207MM (143-326T)	1	Dodge	904090
8	Drive Belts	5VX950 (Position B-M3~34.8 Centers)	2	Dodge	5VX950
9	Shaft Mount Reducer	TA4207H25 (207D25) 25.13-1	1	Dodge	904001
10	Red. Backstop	TA4207BS Backstop Assembly	1	Dodge	904102
11	Red. Taper Bushing	TA4207TB X 2 7/16	1	Dodge	904022
12	Red. Tie Rod	TA4207RA Rod Assembly	1	Dodge	904109
13	Sheave (Reducer)	2/5V9.25-SK (9.15" Pitch)	1	Dodge	455253
14	Bushing	SK-1 7/16	1	Dodge	120428
15	Tail Pulley	16" Dia. X 32" Face "Winged"	1	Precision	W-XPW1632PXT30
16	Take-up Unit	Typ. 24" Travel Truss Type	2	Stephens	12TU200M
17	Tail Bearing	P2B-SCM-207	2	Dodge	126818
18	Tail Shaft	2 7/16" Dia. X 48" Long (Check Length)	1	Stephens	
19	Belt Wiper	30" Titan Belt Wiper Assembly	1	Stephens	WP30STBW19
20	Troughing Idler	30" Troughing Idler 20-Deg		Precision	B4-20TE-30SB
21	Troughing Idler	30" Troughing Idler 35-Deg		Precision	B4-35TE-30SB
22	Return Idler	30" Return Idler		Precision	B4-R-30SB
23	Conveyor Belting				
24	Drive Belt Guard	TA407B/GB		Dodge	904096
25	Tail Pulley Guard	Fabricated in shop			

Conveyor Information	
Shaft RPM	53.3
Conveyor FPM	289.4
Conveyor TPH	529
Sheave Ratio	1.31
Drive Belt HP	40>26

Notes & Revisions

30" Belt: Radial Stacker/Truss 60'-0" to 70'-0" with Screw Take-Ups

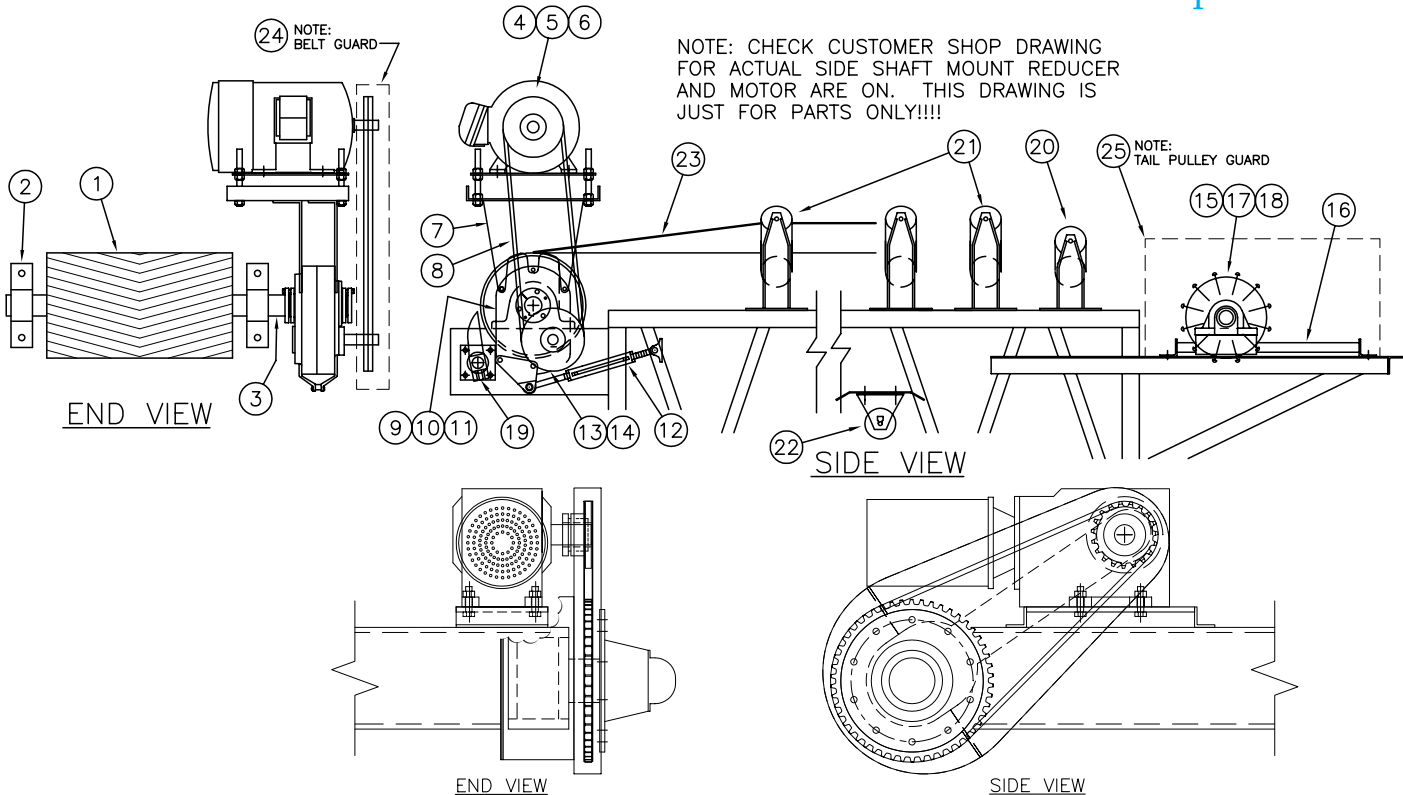

9" Diameter Screw Conveyor with 10 Hp. Motor

Screw Conveyor Reducer Drive 9"

ID	Item	Description	Qty.	Brand	Part#
1	Motor	10 HP - 215T - 1755 RPM	1	Reliance	P21S3027
2	Sheave (Motor)	2/5V4.4-SDS (4.3")	1	Dodge	455240
3	Bushing (Motor)	SDS-1 3/8	1	Dodge	120402
4	Drive Belt	5VX600 (Position A-M2~19.8" Centers)	2	Dodge	SVX600 Belt
5	Motor Mount	TA2115MM (56-256T)	1	Dodge	902090
6	Shaft Mount Reducer	TA2115H05 (115S05) (5.2-1)	1	Dodge	902004
7	Sheave (Reducer)	2/5V8.5-SK (8.4")	1	Dodge	455251
8	Bushing (Reducer)	SK-1 1/8	1	Dodge	120423
9	Adapter & Hardware Kit	TA2115SCA Adaptor	1	Dodge	902070
10	Adjustable Packing Kit	TA2115SCP ADJ. Packing	1	Dodge	902071
11	Drive Shaft	TA2115SCS X 2 Shaft	1	Dodge	903073
12	Drive Belt Guard		1	Stephens	
14	Hanger	2" Hanger Assembly. FMC 226- 9x2	1	Martin	0162-484-6
15	Center Hanger Bearing	2" Hanger Bearing # 220 Martin	1	Martin	CHB2204MHI-0
16	Discharge End Bearing	2" Dia Link Belt Bearing	1	Link	F3U232N
17	Discharge End Shaft				

Notes & Revisions

Conveyor Information	
Shaft RPM	172.73
Conveyor TPH	
Sheave Ratio	1.95
Drive Belt HP	16.4>13

9" Diameter Screw Conveyor with Shaft Mount Reducer

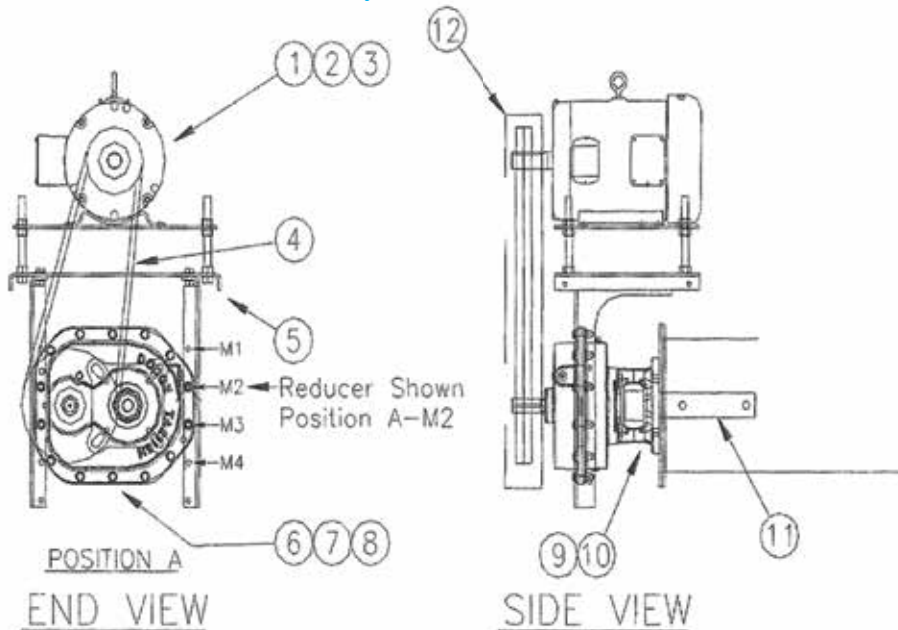

12" Diameter Screw Conveyor with 10 Hp. Motor

ID	Item	Description	Qty.	Brand	Part#
1	Motor	20 HP - 1750 rpm 256T Frame		Reliance	P25S3031
2	Sheave (Motor)	2/5V5.9-SDS (5.8" Pitch)	1	Dodge	455245
3	Bushing (Motor)	SDS-1 5/8	1	Dodge	120406
4	Drive Belt	5VX850 (85" Belt for 26.6" Sheave Centers)	2	Dodge	5VX850 Belt
5	Motor Mount	TA4207H05MM Motor Mount	1	Dodge	904090
6	Shaft Mount Reducer	TA4207H05 (207S05) (5.00-1 Ratio)	1	Dodge	904004
7	Sheave (Reducer)	2/5V14.0-SF (13.9" Pitch)	1	Dodge	455261
8	Bushing (Reducer)	SF-1 7/16- KW Bushing	1	Dodge	120463
9	Adapter & Hardware Kit	TA2115SCA Adaptor	1	Dodge	902070
10	Adjustable Packing Kit	TA2115SCP ADJ. Packing	1	Dodge	902071
11	Drive Shaft	TA3203SCSX3 Drive Shaft	1	Dodge	903075
12	Drive Belt Guard		1	Stephens	Factory made
14	Hanger	3" Hanger Assembly. FMC 226- 12x3	1	Martin	0162-489 L
15	Center Hanger Bearing	3" Hanger Bearing	1	Martin	CHB2206MHI-0
16	Discharge End Bearing	3" Link Belt Bearing	1	Link	F3U2E48N
17	Discharge End Shaft				

Notes & Revisions

Conveyor Information	
Shaft RPM	146.04
Conveyor TPH	
Sheave Ratio	2.4
Drive Belt HP	30.24

12" Diameter Screw Conveyor with Shaft Mount Reducer

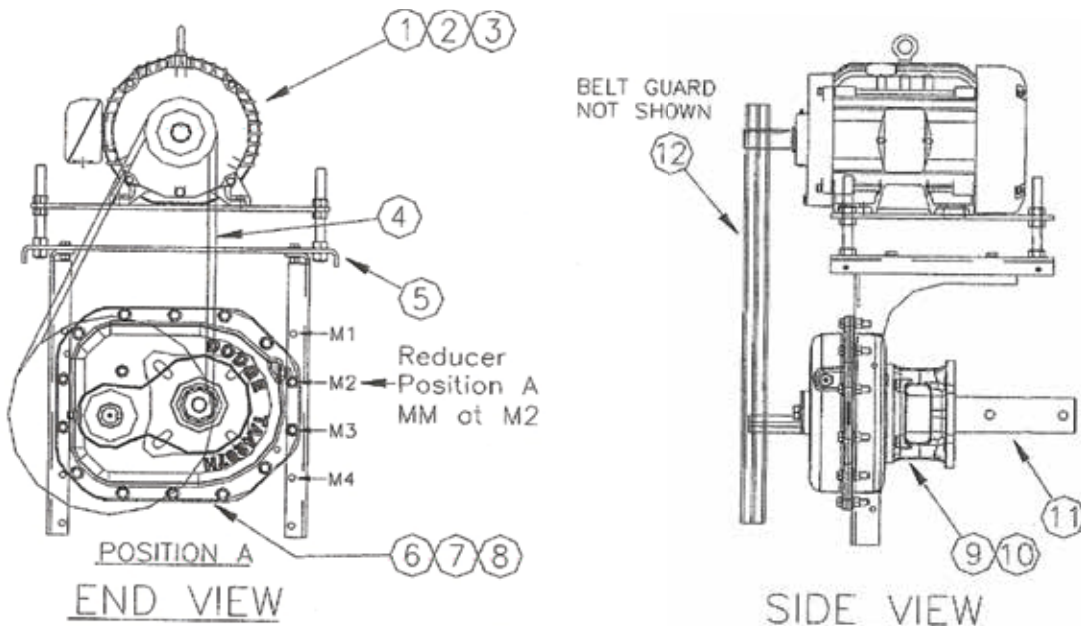

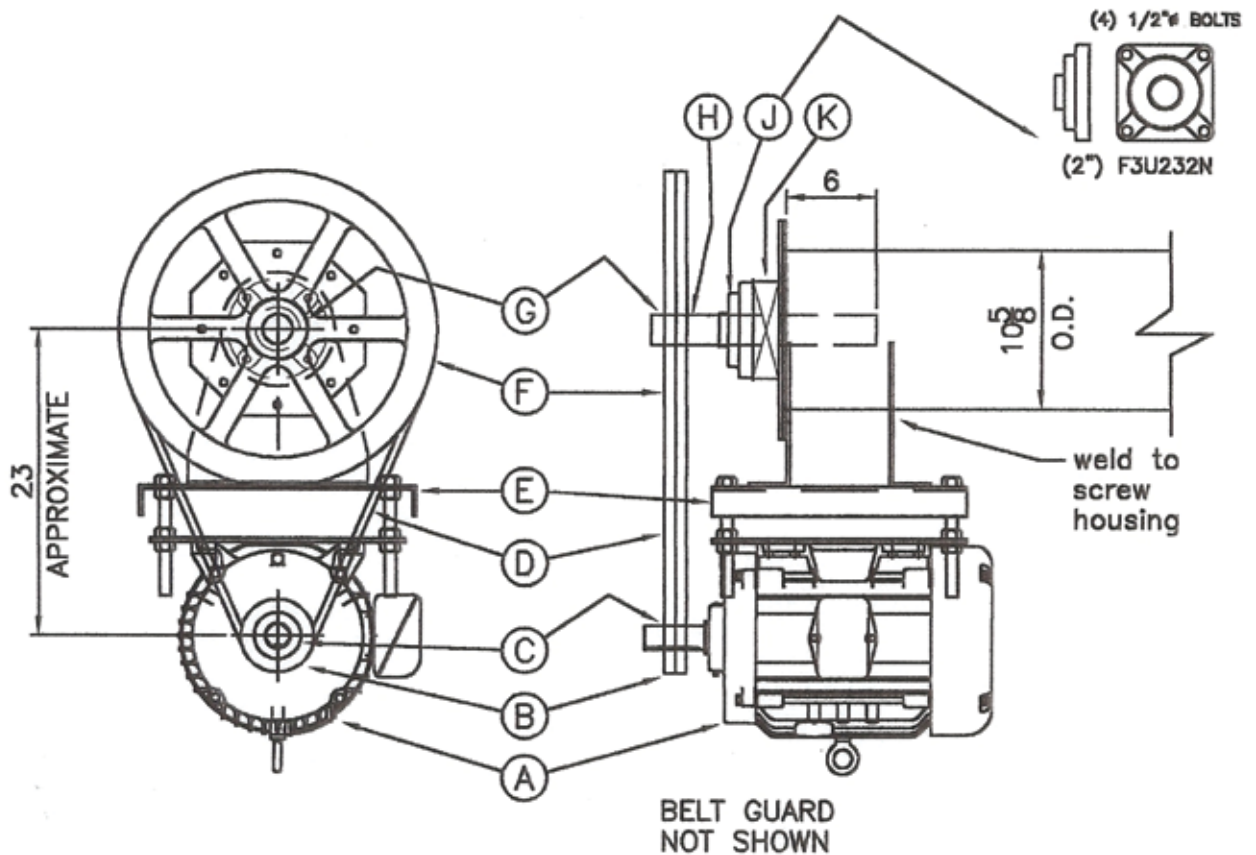

Direct Drive: Shown With Motor Under-Slung

9" Dia. Screw Conveyor with 10HP-256T 1160 RPM Direct Drive Motor

Screw Conveyor Drive Components

ID	Description	Brand	Qty.	Part #
A	10 HP Motor 1160 RPM 256T	Reliance	1	P25S3027
B	2/5V4.9-SDS (4.8") Sheave	Dodge	1	455242
C	SDS-1 5/8 Bushing	Dodge	1	120406
D	5VX900 Belt (90" Belt/23.0" SC)	Dodge	2	5VX900 Belt
E	Stephens made Motor Mount	Stephens	1	
F	2/5V21.2-SF (21.1") Sheave	Dodge	1	455265
G	SF-2 Bushing	Dodge	1	120472
H	2" Dia. Drive Shaft - 15" Long	Stephens	1	
J	2" Dia. Flange Block Bearing	Link-Belt	1	F3U232N
K	2" Dia. Waste Packing Seal	Dodge	1	0121-100-002
K	2" Dia. Rahide Seal	CR	1	19992

Screw Conveyor RPM=264

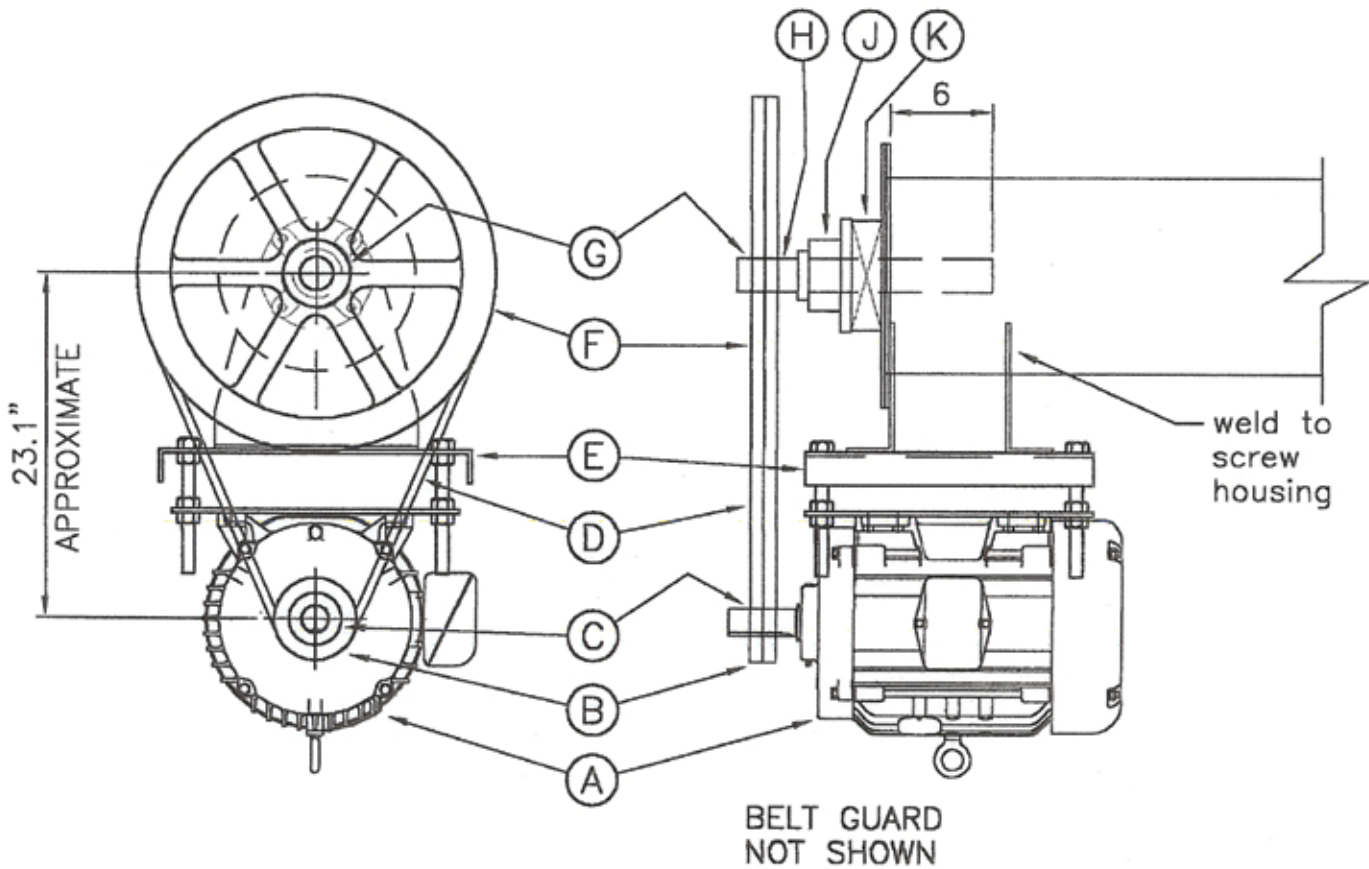

Direct Drive: Shown With Motor Under-Slung

12" Dia. Screw Conveyor with 20HP-286T 1150 RPM Direct Drive Motor

Screw Conveyor Drive Components

ID	Description	Brand	Qty.	Part #
A	20 HP Motor 1150 RPM 286T	Reliance	1	P28S3027
B	4/5V4.90-SD (4.8") Sheave	Dodge	1	455302
C	SD-1 7/8 Bushing	Dodge	1	120386
D	5VX900 Belt (90" Belt/23.1" SC)	Dodge	4	SVX900 Belt
E	Stephens made Motor Mount	Stephens	1	
F	4/5V21.2-E (21.1") Sheave	Dodge	1	455325
G	E-3 Bushing	Dodge	1	120522
H	3" Dia. Drive Shaft - 18" Long	Stephens	1	MH318
J	3" Dia. Flange Block Bearing	Link-Belt	1	F3U2E48N
K	3" Dia. Waste Packing Seal	Dodge	1	0121-102-002

Screw Conveyor RPM=261.6

Screws Conveyor Direct Drive

Mark	Description	9" Part #	12" Part # (15HP)	12" Part # (20Hp)
1	Motor	P21S3027	P25G4902	P25S3031
2	Drive Shaft	2"X15" 1/2 Key Way 6"	3"X15" Turn to 2 7/16"X6	3"X15" Turn 2 7/16" X 6"
3	Motor Sheave	3/5V42	3/5V46	4/5V46
4	Bushing	SK-1 5/8 (120431)	SK-1 7/8 (120435)	SK-1 7/8 (120435)
5	Screw Sheave	3/5V184	3/5V200	4/5V200
6	Bushing	SK-2	SK-2 7/16 (120444)	SK-2 7/16 (120444)
7	Drive Belts	(3) 5V X 800	(3) 5V X 900	(3) 5V X 850
8	Motor Mount Bracket	Special	Special	Special
9	Steel Pipe	2" D.O.M. Tubing	3" D.O.M. Tubing	3" D.O.M Tubing
10	Screw Flighting (1/2 Pich First 5')	2/3 Pitch Remainder	2/3 Pitch Remainder	2/3 Pitch Remainder
11	Hanger Bearing Connection Shaft	2X14	2X14	2X14
12	Hanger Bearing Assembly	F.M.C. 0162-484- C226 (9X2)	0162-489-C226 (12)	0162-489-C226 (12)
13	Hanger Bearing	CNB2204MHI-O Martin 2"	CHB2206MHI-0 (3")	CHB2206MHI-0 (3)
14	Flange Block Bearing	F4BSCM200 (126197)	F4BSCM300 (126917)	F4BSCM300 (126197)
15	Discharge End Shaft	3"X12"	3" X 12"	3" X 12"

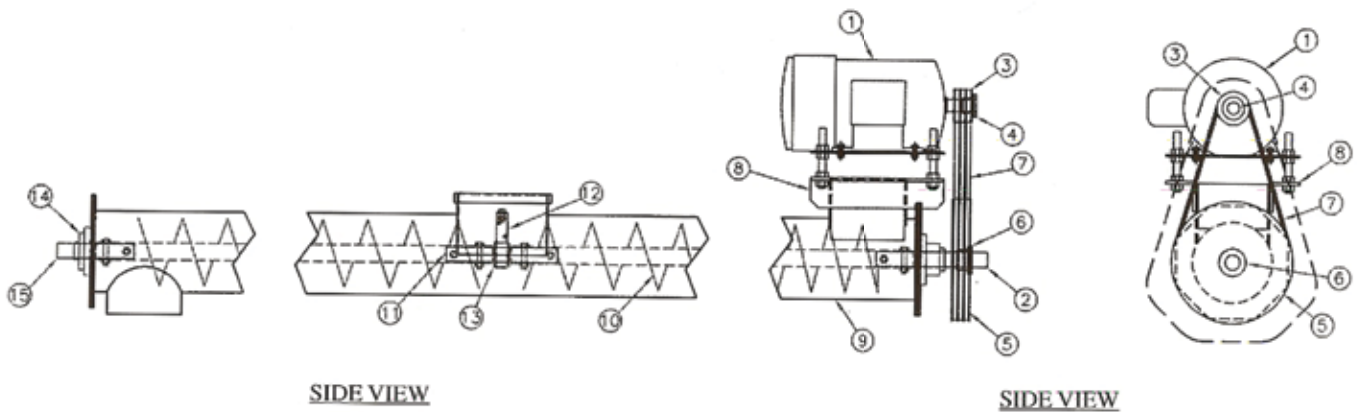

Jackshaft Drive Screw

9"X15- 20' Most Standard Component.
Consult Factory for other Lengths.

Mark	Description	Part #
1	Motor 10 HP 1800RPM	P21S3027
2	Motor Sheave	2TB-36
3	Motor Bushing	P1138
4	Sheave	2TB-124
5	Bushing	Q11
6	Drive Belts	B50
7	Pillow Block Bearing 1"	(123806)
8	Drive Shaft	MH1X18
9	Sprocket	H60P14
10	Bushing	P11
11	Riveted Chain	J60
12	Sprocket	60Q60
13	Bushing	Q12
14	Bearing 2" Link Belt	F3U232N
15	Bearing 2" Link Belt	F3U232N
16	Screw Flighting	2/3 Pitch
17	Shaft	2X 13
18	Shaft	2X 10
19	2" I.D Pipe	2"
20	Hanger Bearing Assembly 2"	0162-484-C
21	Hanger Assembly (Martin) 2"	CHB2204MHI-0
22	2" Waste Packing BRG Flange	0121-100-002

Screw Conveyor Parts Identification

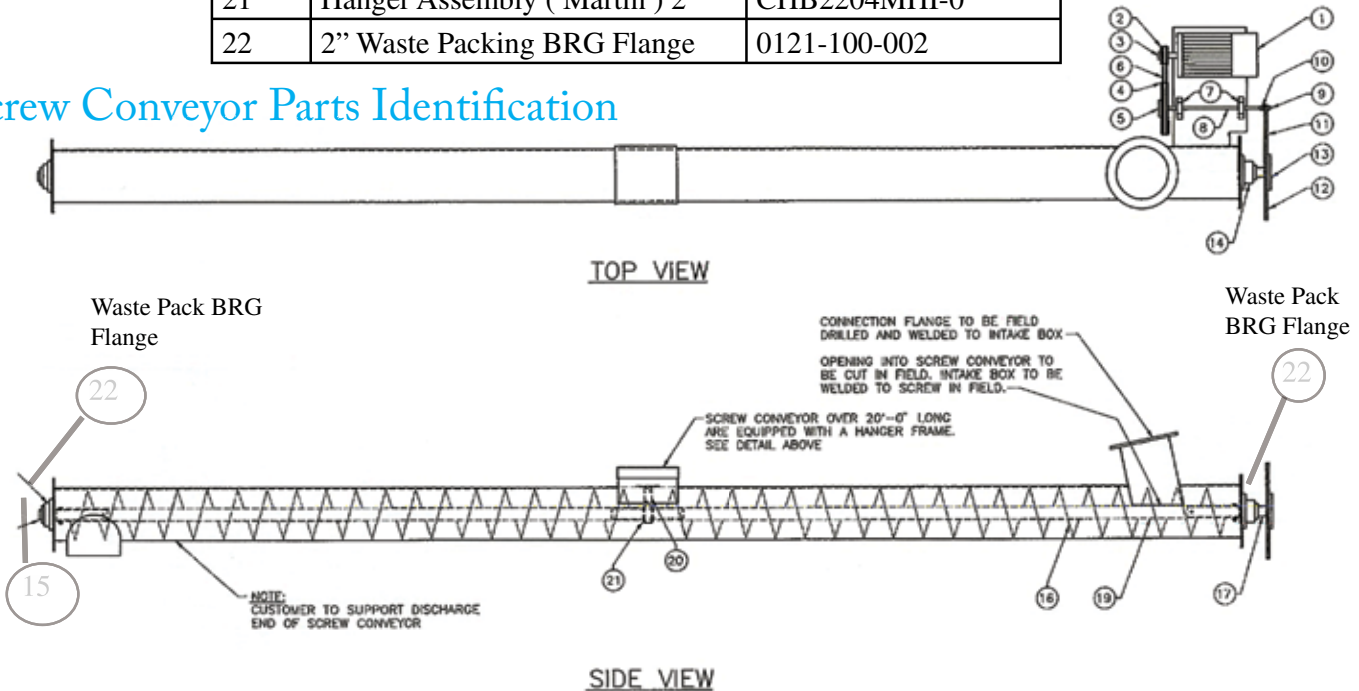

6" AND 9" DIAMETER SCREW CONVEYOR PARTS LIST

NO SCALE

Screw Conveyor Spline Drive



1	ELECTRIC MOTOR
2	(COMPACT) GEAR REDUCER
3	GEAR REDUCER SHAFT SEALING
4	INLET SPOUT
4a	VOLUMETRIC INLET HOPPER
5	TUBULAR HOUSING
6	INSPECTION HATCH
7	INTERMEDIATE BEARING
8	OUTLET END BEARING
9	SPIRAL
10	LIFTING EYE
11	SERIAL NUMBER
12	INLET END BEARING
13	OUTLET SPOUT

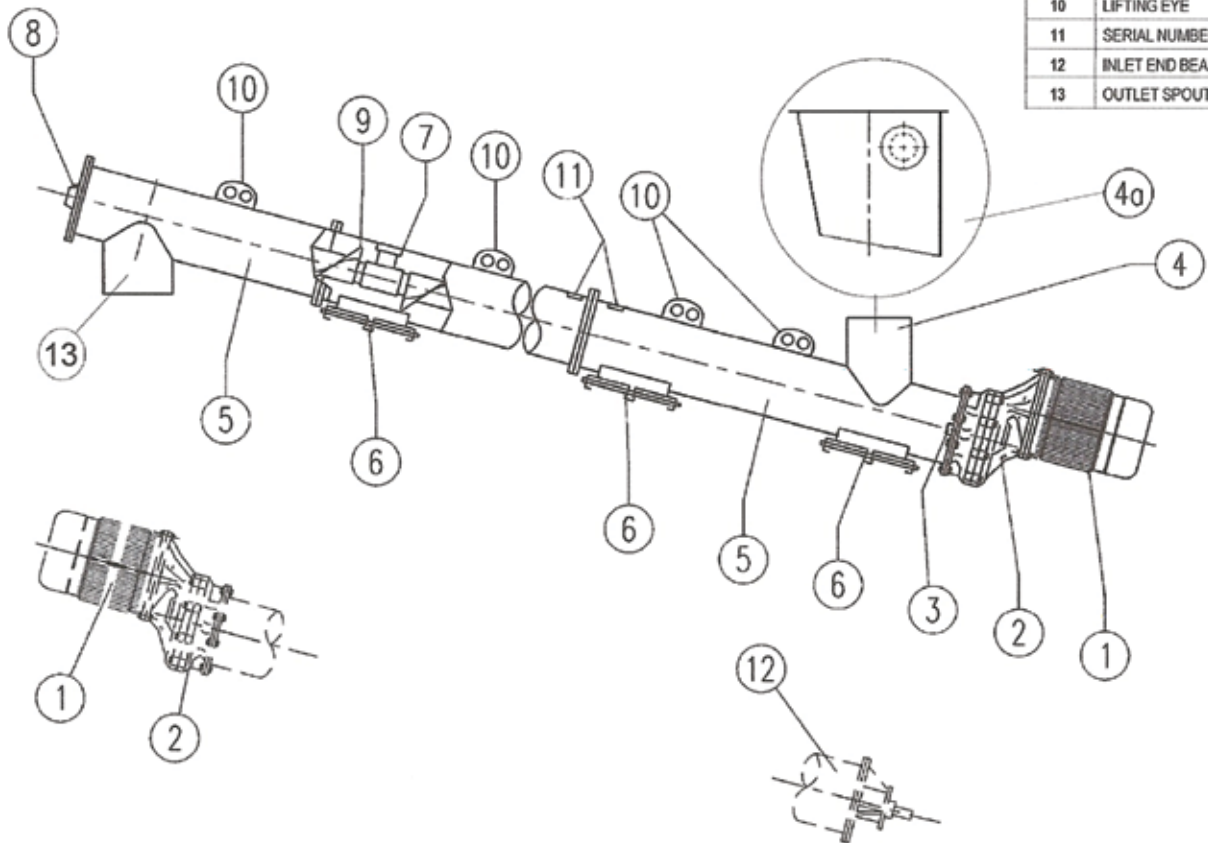

SCREW CONVEYOR COMPONENTS

DESCRIPTION	TRB #:	
RUSTLER 110 Head flight for fill screw (6" dia x 119" lg)	55-78676	 <p style="color: red; font-weight: bold;">TRB# 55-78272</p>
Tail flight for fill screw (6" dia x 117" lg)	55-78675	
Discharge screw for batcher (6" dia x 41" lg)	55-78677	
RUSTLER 160 Standard Head flight for fill screw	55-78633	
Standard Tail flight for fill screw	55-78272	
Tail section assembly	44-126-19082-A1	
Discharge screw for batcher (6" dia x 92" lg)	55-78679	
RUSTLER II Head flight for fill screw (9" dia x 86" lg)	55-79160	
Tail flight for fill screw (9" dia x 87" lg)	55-79159	
RUSTLER R3 Hardware:		 <p style="color: red; font-weight: bold;">TRB# 55-40018</p>
Wood bearing, 2":	55-40018	
Hanger w/ bearing	55-76741	
Head shaft spacer	55-60573-40161-39	 <p style="color: red; font-weight: bold;">TRB# 55-60573-40161-39</p>
BOSS EXEC Head flight for silo screw (9" dia x 144-3/8" lg)	55-79302	
Tail flight for silo screw (9" dia x 190-1/2" lg)	55-79303	
Hardware:		
Coupling shaft field install kit	44-362-325-A1	

SCREW CONVEYOR COMPONENTS

DESCRIPTION	TRB #:	
UNIPLANT 100		
Discharge screw for batcher (6" dia x 69: lg)	55-78338	 TRB# 55-77009
Hardware:		
Tail shaft, 1-1/2" x 9-1/2"	55-77009	 TRB# 55-76936
Coupling shaft, 1-1/2" x 11-1/2"	55-76936	
Bearing hanger, 1-1/2"	55-77317	 TRB# 55-77317
Hard iron bearing, 1-1/2"	55-77008	 TRB# 55-78635
Connecting bolts, 1-1/2" shaft	55-78635	
Head shaft, 1-1/2" x 12-1/2"	55-76946	 TRB# 55-76946
Seal plate, 1-1/2"	55-77104	 TRB# 55-77008
UNIROVER U1248		
Conversion Kit - move reducer from tail to head, Cement side	55-60455-40981	
Conversion Kit - move reducer from tail to head, Fly ash side	55-60455-40982	
Conversion Kit - Reducer adapter, Cement side	55-60455-40961	 TRB# 55-81405
Conversion Kit - Reducer adapter, Fly ash side	55-60455-40962	 TRB# 55-81900
Hardware:		
Wood bearing, 3"	55-81405	
Hanger w/ bearing	55-81900	
C5 adjustable adapter	55-78474	
C4 adjustable adapter	55-78475	 TRB# 55-78474

Plates	Part #
A. 500 x 500 Blind	Plastmatec 050040C
500 x 500 Plate Intermediate	Plastmatec 050040I
500 x 500 Plate Head	Plastmatec 050040F
630 x 630 Plate Blind	Plastmatec 063035C
630 x 630 Plate Intermediate	Plastmatec 063035I
630 x 630 Plate Head	Plastmatec 063035F



Cloths	Part #
500 x 500 Under Cloth Blind	STEMAPURDR10500
500 x 500 Under Cloth Intermediate	STEMAPUDR10500C
500 x 500 Over Cloth Blind	TELMAP003/25X0500
500 x 500 Over Cloth Intermediate	TELMAP003/25XO500C
630 x 630 Under Cloth Blind	STEMADUDR10630
630 x 630 Under Cloth Intermediate	STEMADUDR10630C
630 x 630 Over Cloth Blind	TELMAP003/25X0630
630 x 630 Over Cloth Immediate	TELMAP003/25XCE30C
500 x 500 Over Cloth Blind Reinforced	TELMAT500INCEP00325EDGE
500 x 500 Over Cloth Intermediate Reinforced	TELMAT500INCEP00325EDGE©
630 x 630 Over Cloth Blink Reinforced	TELMAT600INCEP00325EDGE
630 x 630 Over Cloth Intermediate Reinforced	TELMAT630INCEP00325EDGE©
800 x 800 Under Cloth Blind	STEMAPUDR10800
800 x 800 Under Cloth Intermediate	STEMAPUDR10800C
800 x 800 Over Cloth Blind	TELMANS0020800
800 x 800 Over Cloth Intermediate	TELMANS0020800C



Accessories	Part #
2" Wilden Double Diaphragm Pump	P820
B. 2" Ball Valve	S85-08-3-R-R-L
C. 2" Actuator for 2" Ball Valve	921190-113A0532
Solenoid Valve	ELVA4V21006DC24
Shaker Cylinder	CILPNMAGNE032C050
Rebuild Kit for 2" Wilden Pump	08-9824-58-217 (Wet)
Rebuild Kit for 2" Wilden Pump	04-9993-99 (Dry)



HOT WATER TANK PARTS

Solenoid Valves for Make Up Water

3/4" Valve Part # 8210G003

1" Valve Part # 8210G004

1-1/4" Valve Part # 8210G008

1-1/2" Valve Part # 8210G022

2" Valve Part #8210G100

Rebuild Kit for 1 1/4" valve part #302280

Rebuild Kit for 1 1/2" valve part #302284

Coil for 1 1/4 -1 1/2" valve part #23810-032-D

Complete Pearson Temperature Control #TS-HW

(Pearson Digital Temperature Control Standard on all Hot Water Heaters)

Digital Temperature Control with thermowell, probe, enclosure & wires

Pearson Temp Control (just control) #TS-13010

Temp Control Well

Temp Control Probe

Float Switches High and Low Water Switches in all Pearson Hot Water Heaters

Float Switch #683 (high/low)

Replacement Diaphragm #Buna-N 000701-P

Replacement Micro Switch #000602 -P

Replacement SS Float #00042-P

McDonnell Miller #69 float switch Infern O Therm tanks

Fuel Filter (per burner)

General Filter 2A-700B

Sight Glass Replacement

High temperature plastic tube for water sight glass

Thermometer for Hot Water Tanks

3" dial 9" stem 0-24 deg F #B8320905

Flow Meters for Hot Water Tanks:

Flow Meter FL-515-PLSF 0-15GPM 1" 2W&3W burners

Digital Flow Meter RB-150ST Flow 15-150 GPM 1-1/2" 10Wthru 25W

Anode Rods 1" x 6' rod.....



Globe Valves for throttling make up water flow

1" bronze globe valve 2-3W burners #1BGV

1 ½ " bronze globe valve 6-25W burners #1.5BGV

1 ½" Cast iron Y strainer #1.5 YS

Burner Mounting Plate

18" Firetube Plate

20" Firetube Plate

24" Firetube Plate

Burner Plate Gaskets

18" Firetube Plate Gasket

20" Firetube Plate Gasket

24" Firetube Plate Gasket

Square Burner Mounting Gasket

CR1 Burner

CR2 Burner

CR3 Burner

30" Side Manway Gasket

35" blank gasket

Inswall Board

18" Firetube

20" Firetube

24" Firetube

Water Pump Parts

Pearson Heaters had Scot pumps standard since 2004 pricing below is for Scot pumps.

Other brands available upon request

Seal repair kit for 10 hp and 7.5 hp pump #118.000.344

Seal repair kit for 5 hp pump #118.000.343

Burner Parts

All Pearson Hot Water Heaters use Powerflame Burners. Each burner is built for a specific job and fuel. Please refer to your burner As Built Sheet for part numbers and contact Pearson Heating for pricing. If you do not have your As Built Sheet please provide Pearson with the burner "J number" found on the burner rating tag or the Pearson serial number found on the build plate on the tank.

Toku Equipment

	Part #
Chipping Hammer #19	TCH-3
Rivet Buster #35	RB-110
Rivet Buster #23	K-600
Rivet Buster #31	K-800



Brunner-Lay Bits

	Part #
Chipping Hammer Point 1	L02J12
Chipping Hammer 1" Chisel	L03J12
Chipping Hammer 2" Chisel	L11J1R
Rivet Buster Point	L11B12
Rivet Buster 1" Chisel	L22B12
Air Hose 50' x 3/4 - 300 PSI	3/4X50FT



Tanner Gas

	Part #
1/2 Gallon Dispenser	T85
1 Quart Dispenser	T90
Tanner Gas Liquid 5 Gallon	TG05



Rental Items



Air Compressors



Redline 110V Ice/Fibers Conveyor

RM 23 Undercarriage

Item#	Description
A1	2.5 x 18" Tie Rod Lift Cylinder
A2	1/4" Hydraulic Hose w/Fittings
A3	Hydraulic Hand Pump HP121
A4	Lift Jack
A5	3000 lb. x 72" Hub Face Axle with Idler Hubs - 5 lug

RM 23 Conveyor

Item#	Description
B1	8 x 20 Lagged Drive Pulley x 1-7/16" Bushings
B2	237 Drive shaft for 1-1/4" hollow bore gearbox
B3	1-7/16" 4 bolt Flange bearing
B4	4 blot adjuster plate with adjuster bolt
B5	Adjuster bracket for 5/8" adjuster bolt
B6	237 0 30:1 Gearbox 56 Frame
B7	56C Electric Motor - please specify model/voltage
B8	Gearbox Mount Bracket
B9	8 x 20 Winged Tail Pulley x 1-1/4" Bushings
B10	1-1/4" Shaft for Tail Pulley
B11	1-1/4" Take-up bearing
B12	3/4" Take-up Bolt with Hex Nit, spring pin
B13	Bearing take-up Bracket
B14	20 degree x 18" belt trough idler DCL-18-20-04
B15	35 degree x 18" belt trough idler DCL-18-35-04
B16	Return Roller Idler
B17	5/8" Pillow Block bearing for Return Roller
B18	RM-Series Loading Hopper
B19	Saddle Bracket
B20	RM23 x 18" Steep Climb belt
B21	On/Off Switch for 110V

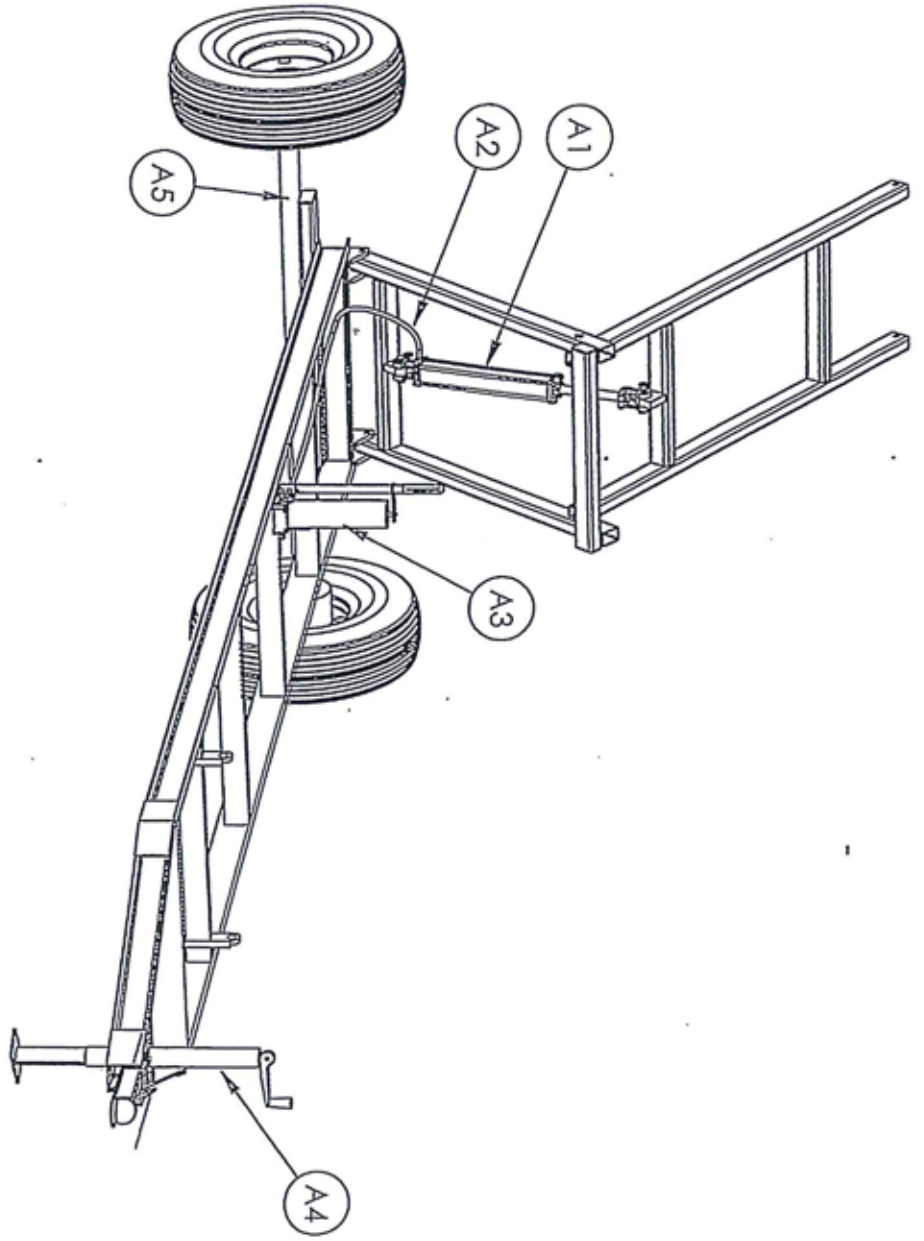

Redline
SYSTEMS INC
500 SOUTH MAIN STREET
CLEARFIELD, UT 84015
800-453-2447
EMAIL: INFO@REDLINECONVEYORS.COM

NAME: CIP DATE: 9/5/2017 TITLE: RM 23 Undercarriage

DRAWN BY: MATERIAL: SIZE: PART NO. A REV: SCALE: 1:20 SHEET 1 OF 2

Redline Conveyors

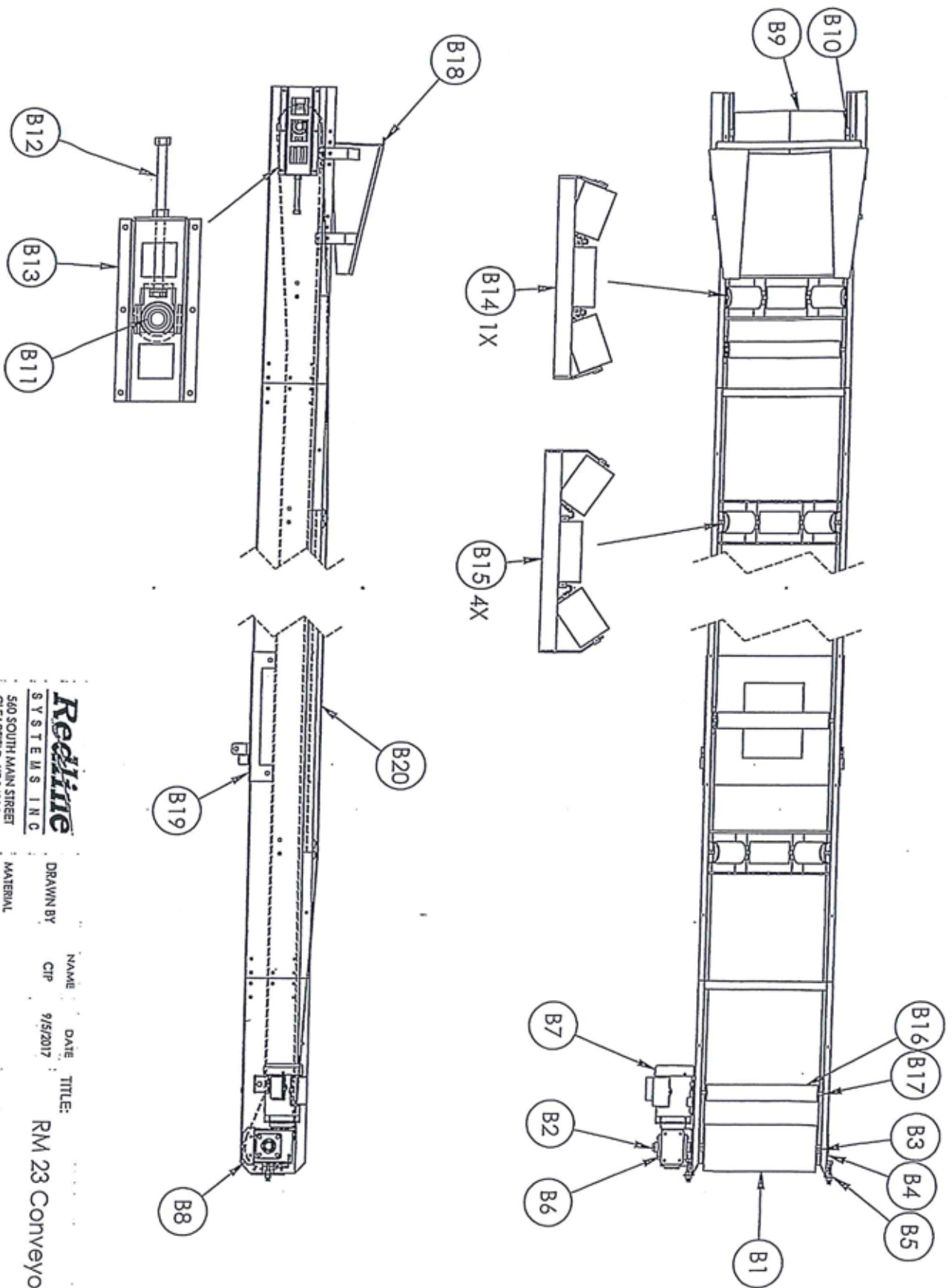

3

9

Redline
S Y S T E M S I N C

540 SOUTH MAIN STREET
CLEARFIELD, UT 84015
800-453-2447
EMAIL: INFO@REDLINECONVEYORS.COM

DRAWN BY: CIP NAME: CIP DATE: 9/5/2017

MATERIAL: TITLE: RM 23 Conveyor

SIZE - PART NO. REV

A

SCALE: 1:25 SHEET 2 OF 2

WORKHORSE PARTS

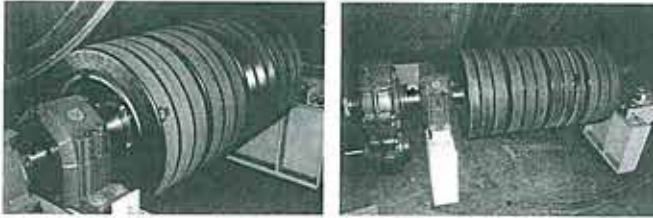

WP-10-900-00200 HUB ASSEMBLY - COMPLETE WITH POWER LOCKING DEVICE; WITHOUT SHAFT

SHAFT ONLY - WP6.47/6X76.5



22X10X16 - POLYURETHANE TIRES



PL150X200 POWER LOCK DEVICE



SPLIT BEARING = 041874
ONE PIECE BEARING & SEALS = WP-10-900-00220



WP-10-L00010214 CHARGING SEAL



WP-10-L00010311 DISCHARGE SEAL



ML-IV-09FC3-Y8S CHARGING CHUTE LINER



ML-IV-09MXC-T8S MIXER DRUM LINER



CMW EQUIPMENT

8668 Olive Blvd.

St. Louis, MO 63132

314-993-1336 - Office

314-993-1467 - Fax



Arkansas Ready Mixed Concrete Association

www.cmw-equip.com